



ETA-Danmark A/S
Göteborg Plads 1
DK-2150 Nordhavn
Tel. +45 72 24 59 00
Fax +45 72 24 59 04
Internet www.etadanmark.dk

Authorised and notified according
to Article 29 of the Regulation (EU)
No 305/2011 of the European
Parliament and of the Council of 9
March 2011

MEMBER OF EOTA



European Technical Assessment ETA-11/0024 of 2022/08/25

I General Part

Technical Assessment Body issuing the ETA and designated according to Article 29 of the Regulation (EU) No 305/2011: ETA-Danmark A/S

Trade name of the construction product:

E.u.r.o. Tec screws type KonstruX”, “Paneltwistec”, “Topduo”, “Terrassotec”, “SP FK”, “Speedo”, “Hobotec”, “Hapatec”, “SP ZK”, “Ecotec”, “WBS”, “Sawtec”, “FBAS”, “VSS”, “Duratec” and “LBS” screws and “BRUTUS” threaded rods

Product family to which the above construction product belongs:

Screws for use in timber constructions

Manufacturer:

E.u.r.o. Tec GmbH
Unter dem Hofe 5
D-58099 Hagen
Tel. +49 2331 / 6245 - 0
Fax +49 2331 / 6245 - 200
Internet www.eurotec.team

Manufacturing plant:

Held on file by ETA-Danmark A/S

This European Technical Assessment contains:

56 pages including 5 annexes which form an integral part of the document

This European Technical Assessment is issued in accordance with Regulation (EU) No 305/2011, on the basis of:

European Assessment document (EAD) no. EAD 130118-01-0603 “Screws and threaded rods for timber constructions”

This version replaces:

The previous ETA with the same number issued on 2021-06-23

Translations of this European Technical Assessment in other languages shall fully correspond to the original issued document and should be identified as such.

Communication of this European Technical Assessment, including transmission by electronic means, shall be in full (excepted the confidential Annex(es) referred to above). However, partial reproduction may be made, with the written consent of the issuing Technical Assessment Body. Any partial reproduction has to be identified as such.

II SPECIFIC PART OF THE EUROPEAN TECHNICAL ASSESSMENT

1 Technical description of product

Technical description of the product

E.u.r.o.Tec “KonstruX”, “Paneltwistec”, “Topduo“, “Terrassotec“, “SP FK”, “Speedo”, “Hobotec”, “Hapatec”, “SP ZK”, “Ecotec”, “WBS”, “VSS”, “Sawtec”, “FBAS”, “Duratec” and “LBS” screws and BRUTUS threaded rods are self-tapping screws to be used in timber structures. E.u.r.o.Tec “Paneltwistec”, “Topduo“, “Terrassotec“, “SP FK”, “Speedo”, “Hobotec”, “Hapatec”, “SP ZK”, “Sawtwc”, “FBAS” and “Duratec” screws shall be threaded over a part of the length. E.u.r.o.Tec “KonstruX”, “WBS” “VSS” and BRUTUS threaded rods screws shall be threaded over the full length. E.u.r.o.Tec “Ecotec” and “LBS” screws may be threaded over a part or over the full length. The screws shall be produced from carbon steel wire for nominal diameters of 3,5 mm to 12,0 mm and from stainless steel wire for nominal diameters of 3,5 mm to 10,0 mm. The nominal diameter of BRUTUS threaded rods is 16 mm. Where corrosion protection is required, the material or coating shall be declared in accordance with the relevant specification given in Annex A of EN 14592.

Geometry and Material

The nominal diameter (outer thread diameter), d , shall not be less than 3,5 mm and shall not be greater than 16,0 mm. The overall length, L , of screws shall not be less than 25 mm and shall not be greater than 1000 mm. The overall length of the threaded rods shall not be greater than 3000 mm. Other dimensions are given in Annex A.

The ratio of inner thread diameter to outer thread diameter d_i/d ranges from 0,57 to 0,77.

The screws are threaded over a minimum length ℓ_g of $4 \cdot d$ (i.e. $\ell_g \geq 4 \cdot d$).

The lead p (distance between two adjacent thread flanks) ranges from $0,38 \cdot d$ to $0,97 \cdot d$.

No breaking shall be observed at a bend angle, α , of less than $(45/d^{0.7} + 20)$ degrees.

2 Specification of the intended use in accordance with the applicable European Assessment Document (hereinafter EAD)

The screws and threaded rods are used for connections in load bearing timber structures between members of solid timber (softwood), glued laminated timber, cross-laminated timber, and laminated veneer lumber (softwood and hardwood), similar glued members, wood-based panels or steel. E.u.r.o. Tec “KonstruX” screws and BRUTUS threaded rods are also used as tensile or compressive reinforcement perpendicular to the grain.

Furthermore E.u.r.o. Tec screws with diameters between 6 mm and 12 mm may also be used for the fixing of thermal insulation on rafters.

Steel plates and wood-based panels except solid wood panels, LVL and cross laminated timber shall only be located on the side of the screw head. The following wood-based panels may be used:

- Plywood according to EN 636 or ETA
- Particleboard according to EN 312 or ETA
- Oriented Strand Board, Type OSB/3 and OSB/4 according to EN 300 or ETA
- Fibreboard according to EN 622-2 and 622-3 or ETA (minimum density 650 kg/m³)
- Cement bonded particleboard
- Solid wood panels according to EN 13353 and EN 13986 and cross laminated timber according to ETA
- Laminated Veneer Lumber, LVL
- FST according to ETA-14/0354
- Engineered wood products according to ETA, provided that the ETA for the product provides provisions for the use of self-tapping screws and these provisions are applied

The screws shall be driven into the wood without pre-drilling or after pre-drilling with a diameter not larger than the inner thread diameter for the length of the threaded part and with a maximum of the smooth shank diameter for the length of the smooth shank. The threaded rods and the stainless steel KonstruX screws shall be driven into softwood after pre-drilling with the following diameter:

Threaded rod 16 mm: Pre-drilling diameter 13 mm.

KonstruX 10 mm austenitic stainless steel: Pre-drilling diameter 6 mm.

Threaded rods or 10 mm KonstruX screws made from stainless steel shall only be driven into pre-drilled holes.

The screws are intended to be used in timber connections for which requirements for mechanical resistance and

stability and safety in use in the sense of the Basic Works Requirements 1 and 4 of Regulation 305/2011 (EU) shall be fulfilled.

The design of the connections shall be based on the characteristic load-carrying capacities of the screws. The design capacities shall be derived from the characteristic capacities in accordance with Eurocode 5 or an appropriate national code.

The screws are intended for use for connections subject to static or quasi static loading.

Section 3.11 of this ETA contains the corrosion protection for E.u.r.o. Tec screws made from carbon steel and the material number of the stainless steel. The martensitic stainless steel screws are for use in timber structures subject to the conditions defined by the service classes 1, 2 and 3 of EN 1995-1-1 (Eurocode 5).

The scope of the screws regarding resistance to corrosion shall be defined according to national provisions that apply at the installation site considering environmental conditions.

The provisions made in this European Technical Assessment are based on an assumed intended working life of the screws of 50 years.

The indications given on the working life cannot be interpreted as a guarantee given by the producer or Assessment Body, but are to be regarded only as a means for choosing the right products in relation to the expected economically reasonable working life of the works.

3 Performance of the product and references to the methods used for its assessment

Characteristic	Assessment of characteristic
3.1 Mechanical resistance and stability*) (BWR1)	
Tensile strength	Characteristic value $f_{\text{tens,k}}$:
Screws made of carbon steel or stainless steel hardened (martensitic stainless steel) except KonstruX and LBS	Screw d = 3,5 mm: 3,8 kN Screw d = 4,0 mm: 5,0 kN Screw d = 4,5 mm: 6,4 kN Screw d = 5,0 mm: 7,9 kN Screw d = 6,0 mm: 11 kN Screw d = 8,0 mm: 20 kN Screw d = 10,0 mm: 28 kN Screw d = 12,0 mm: 25 kN
KonstruX screws made of carbon steel	Screw d = 6,5 mm: 17 kN Screw d = 8,0 mm: 25 kN Screw d = 9,0 mm: 30 kN Screw d = 10,0 mm: 33 kN Screw d = 11,3 mm: 50 kN
LBS screws made of carbon steel	Screw d = 8,0 mm: 30 kN
Screws made of stainless steel unhardened (austenitic stainless steel A2 and A4)	Screw d = 3,5 mm: 2,1 kN Screw d = 4,0 mm: 2,8 kN Screw d = 4,5 mm: 3,5 kN Screw d = 4,8 mm: 5,0 kN Screw d = 5,0 mm: 4,3 kN Screw d = 5,5 mm: 6,0 kN Screw d = 6,0 mm: 6,2 kN Screw d = 6,5 mm: 10 kN Screw d = 8,0 mm: 16 kN Screw d = 10,0 mm: 20 kN
BRUTUS threaded rod	Rod d = 16 mm: 115 kN
Insertion moment	Ratio of the characteristic torsional strength to the mean insertion moment: $f_{\text{tor,k}} / R_{\text{tor,mean}} \geq 1,5$
Torsional strength	Characteristic value $f_{\text{tor,k}}$:
Screws made of carbon steel or stainless steel hardened (martensitic stainless steel) except KonstruX and LBS	Screw d = 3,5 mm: 2,0 Nm Screw d = 4,0 mm: 3,0 Nm Screw d = 4,5 mm: 4,2 Nm Screw d = 5,0 mm: 7,5 Nm Screw d = 6,0 mm: 9,5 Nm Screw d = 8,0 mm: 22 Nm Screw d = 10,0 mm: 40 Nm Screw d = 12,0 mm: 60 Nm
KonstruX screws made of carbon steel	Screw d = 6,5 mm: 19 Nm Screw d = 8,0 mm: 28 Nm Screw d = 9,0 mm: 51 Nm Screw d = 10,0 mm: 48 Nm Screw d = 11,3 mm: 80 Nm
LBS screws made of carbon steel	Screw d = 8,0 mm: 40 Nm

Characteristic	Assessment of characteristic
Screws made of stainless steel unhardened (austenitic stainless steel A2 and A4)	Screw d = 3,5 mm: 1,2 Nm Screw d = 4,0 mm: 1,8 Nm Screw d = 4,5 mm: 2,5 Nm Screw d = 4,8 mm: 4,3 Nm Screw d = 5,0 mm: 3,4 Nm Screw d = 5,5 mm: 5,0 Nm Screw d = 6,0 mm: 5,7 Nm Screw d = 6,5 mm: 10,0 Nm Screw d = 8,0 mm: 18,0 Nm Screw d = 10,0 mm: 28,0 Nm
BRUTUS threaded rod	Rod d = 16 mm: 180 Nm
3.2 Safety in case of fire (BWR2)	
Reaction to fire	The screws are made from steel classified as performance class A1 of the characteristic reaction to fire, in accordance with the provisions of EC decision 96/603/EC, amended by EC Decision 2000/605/EC.
3.3 General aspects related to the performance of the product	The screws have been assessed as having satisfactory durability and serviceability when used in timber structures using the timber species described in Eurocode 5 and subject to the conditions defined by service classes 1, 2 and 3
Identification	See Annex A

*) See additional information in section 3.4 – 3.6.

3.4 Mechanical resistance and stability

The load-carrying capacities for E.u.r.o.Tec screws are applicable to the wood-based materials mentioned in paragraph 1 even though the term timber has been used in the following.

The characteristic lateral load-carrying capacities and the characteristic axial withdrawal capacities of E.u.r.o.Tec screws should be used for designs in accordance with Eurocode 5 or an appropriate national code.

For screws arranged under an angle between screw axis and grain direction $\alpha \leq 15^\circ$, the minimum threaded penetration length is: $\ell_{ef} \geq \min(4 \cdot d / \sin \alpha; 20 \cdot d)$. For $15^\circ < \alpha \leq 90^\circ$ the minimum threaded must be $\ell_{ef} \geq 4 \cdot d$. For the fixing of rafters, point side penetration must be at least 40 mm, $\ell_{ef} \geq 40$ mm.

The mathematical penetration length of the threaded rods shall be limited to 1000 mm even if the actual penetration length is longer.

ETA's for structural members or wood-based panels must be considered where applicable.

Lateral load-carrying capacity

The characteristic lateral load-carrying capacity of E.u.r.o.Tec screws or threaded rods shall be calculated according to Eurocode 5 using the outer thread diameter d as the nominal diameter of the screw. The contribution from the rope effect may be considered.

For steel-to-timber connections with "WBS" screws $d = 5$ mm, a thick steel plate may be assumed for steel plate thickness $t \geq 2,0$ mm.

The characteristic yield moment shall be calculated from:

E.u.r.o.Tec screws for $3,5 \text{ mm} \leq d \leq 10,0 \text{ mm}$ made of carbon steel or stainless steel hardened martensitic stainless steel except KonstruX:
 $M_{y,k} = 0,15 \cdot 600 \cdot d^{2,6}$ [Nmm]

Paneltwistec screws:

Screw $d = 12,0$ mm: 40000 Nmm

E.u.r.o.Tec threaded rods:

Rod $d = 16,0$ mm: 240000 Nmm

E.u.r.o.Tec KonstruX screws made of carbon steel:

Screw $d = 6,5$ mm: 15000 Nmm

Screw $d = 8,0$ mm: 25000 Nmm

Screw $d = 9,0$ mm: 40000 Nmm

Screw $d = 10,0$ mm: 40000 Nmm

Screw $d = 11,3$ mm: 70000 Nmm

E.u.r.o.Tec LBS screws:

Screw $d = 8,0$ mm: 35000 Nmm

E.u.r.o.Tec screws for $3,5 \text{ mm} \leq d \leq 10,0 \text{ mm}$ made of stainless steel (austenitic stainless steel A2 and A4) except FBAS and KonstruX:
 $M_{y,k} = 0,15 \cdot 320 \cdot d^{2,6}$ [Nmm]

E.u.r.o.Tec FBAS screws:

Screw $d = 4,8$ mm: 3800 Nmm

Screw $d = 5,5$ mm: 5000 Nmm

E.u.r.o.Tec KonstruX screws made of austenitic stainless steel:

Screw $d = 6,5$ mm: 10000 Nmm

Screw $d = 8,0$ mm: 16000 Nmm

Screw $d = 10,0$ mm: 26000 Nmm

where

d outer thread diameter [mm]

The embedding strength for screws in non-pre-drilled holes in softwood arranged at an angle between screw axis and grain direction, $0^\circ \leq \alpha \leq 90^\circ$ is:

$$f_{h,k} = \frac{0,082 \cdot \rho_k \cdot d^{-0,3}}{2,5 \cdot \cos^2 \alpha + \sin^2 \alpha} \quad [\text{N/mm}^2]$$

and accordingly for screws in pre-drilled holes:

$$f_{h,k} = \frac{0,082 \cdot \rho_k \cdot (1 - 0,01 \cdot d)}{2,5 \cdot \cos^2 \alpha + \sin^2 \alpha} \quad [\text{N/mm}^2]$$

Where

ρ_k characteristic timber density [kg/m^3];

d outer thread diameter [mm];

α angle between screw axis and grain direction.

The embedding strength for screws arranged parallel to the plane of cross laminated timber, independent of the angle between screw axis and grain direction, $0^\circ \leq \alpha \leq 90^\circ$, may be calculated from:

$$f_{h,k} = 20 \cdot d^{-0,5} \quad [\text{N/mm}^2]$$

Where

d outer thread diameter [mm]

The embedding strength for screws or threaded rods in the wide face of cross laminated timber should be assumed as for solid timber based on the characteristic density of the outer layer. If relevant, the angle between force and grain direction of the outer layer should be taken into account.

The direction of the lateral force shall be perpendicular to the screw axis and parallel to the wide face of the cross laminated timber.

The embedding strength for screws in non-pre-drilled holes in softwood LVL arranged at an angle between screw axis and grain direction, $0^\circ \leq \alpha \leq 90^\circ$ is:

$$f_{h,k} = \frac{0,082 \cdot \rho_k \cdot d^{-0,3}}{(2,5 \cdot \cos^2 \alpha + \sin^2 \alpha)(1,5 \cdot \cos^2 \beta + \sin^2 \beta)} \quad [\text{N/mm}^2]$$

and accordingly for screws in pre-drilled holes in softwood LVL:

$$f_{h,k} = \frac{0,082 \cdot \rho_k \cdot (1 - 0,01 \cdot d)}{(2,5 \cdot \cos^2 \alpha + \sin^2 \alpha)(1,5 \cdot \cos^2 \beta + \sin^2 \beta)} \quad [\text{N/mm}^2]$$

Where

- ρ_k characteristic timber density [kg/m^3];
 d outer thread diameter [mm];
 α angle between screw axis and grain direction;
 β angle between screw axis and the LVL's wide face ($0^\circ \leq \alpha \leq 90^\circ$).

The embedding strength for screws in pre-drilled or non-pre-drilled holes in Beech LVL according to EN 14374 or in FST according to ETA-14/0354 is:

$$f_{h,k} = \frac{0,082 \cdot \rho_k \cdot d^{-0,15}}{(2,5 \cdot \cos^2 \alpha + \sin^2 \alpha) \cdot k_\varepsilon \cdot k_\beta} \quad [\text{N/mm}^2]$$

Where

- ρ_k characteristic density [kg/m^3];
 d outer thread diameter [mm];
 α angle between screw axis and grain direction, $0^\circ \leq \alpha \leq 90^\circ$;
 $k_\varepsilon = (0,5 + 0,024 \cdot d) \cdot \sin^2 \varepsilon + \cos^2 \varepsilon$;
 ε angle between load and grain direction; $0^\circ \leq \varepsilon \leq 90^\circ$;
 $k_\beta = 1,2 \cdot \cos^2 \beta + \sin^2 \beta$;
 β angle between screw axis and wide face of LVL or FST member, $0^\circ \leq \beta \leq 90^\circ$.

Axial withdrawal capacity

The characteristic axial withdrawal capacity of E.u.r.o.Tec screws in solid timber (softwood), glued laminated timber or cross-laminated timber members at an angle of $0^\circ \leq \alpha \leq 90^\circ$ (screws without tip type BS or Paneltwistec or KonstruX screws in Beech LVL or FST according to ETA-14/0354) or $30^\circ \leq \alpha \leq 90^\circ$ (screws with tip type BS) to the grain shall be calculated from:

$$F_{ax,\alpha,Rk} = \frac{n_{ef} \cdot k_{ax} \cdot f_{ax,k} \cdot d \cdot \ell_{ef} \left(\frac{\rho_k}{\rho_a} \right)^{0,8}}{k_\beta} \quad [\text{N}]$$

Where

- $F_{ax,\alpha,Rk}$ characteristic withdrawal capacity of the group of screws at an angle α to the grain [N]
 n_{ef} effective number of screws according to EN 1995-1-1:2008
 k_{ax} $k_{ax} = 1,0$ for $45^\circ \leq \alpha \leq 90^\circ$
 $k_{ax} = a + \frac{b \cdot \alpha}{45^\circ}$ for $0^\circ \leq \alpha < 45^\circ$
 $a = \begin{cases} 0,5 & \text{for LVL or FST} \\ 0,3 & \text{for timber} \end{cases}$

$$b = \begin{cases} 0,5 & \text{for LVL or FST} \\ 0,7 & \text{for timber} \end{cases}$$

- k_β $k_\beta = 1,0$ for timber
 $k_\beta = 1,5 \cdot \cos^2 \beta + \sin^2 \beta$ for LVL or FST
 $f_{ax,k}$ Characteristic withdrawal parameter
Screws with tip type BS in softwood and $\rho_a = 350 \text{ kg/m}^3$:
Screw $d \leq 10 \text{ mm}$: $f_{ax,k} = 9,0 \text{ N/mm}^2$
Screw $d = 11,3 \text{ mm}$: $f_{ax,k} = 8,0 \text{ N/mm}^2$
Screws without tip type BS in softwood and $\rho_a = 350 \text{ kg/m}^3$:
Screw $d = 3,5 \text{ mm}$: $f_{ax,k} = 13,3 \text{ N/mm}^2$
Screw $d = 4,0 \text{ mm}$: $f_{ax,k} = 12,9 \text{ N/mm}^2$
Screw $d = 4,5 \text{ mm}$: $f_{ax,k} = 12,5 \text{ N/mm}^2$
Screw $d = 5,0 \text{ mm}$: $f_{ax,k} = 12,1 \text{ N/mm}^2$
Screw $d = 6,0 \text{ mm}$: $f_{ax,k} = 11,4 \text{ N/mm}^2$
Screw $d = 6,5 \text{ mm}$: $f_{ax,k} = 11,4 \text{ N/mm}^2$
Screw $d = 8,0 \text{ mm}$: $f_{ax,k} = 11,1 \text{ N/mm}^2$
Screw or threaded rod $d \geq 10,0 \text{ mm}$: $f_{ax,k} = 10,8 \text{ N/mm}^2$
Paneltwistec, Duratec or KonstruX screws in softwood LVL and $\rho_a = 500 \text{ kg/m}^3$:
Screw $5 \text{ mm} \leq d \leq 12 \text{ mm}$: $f_{ax,k} = 15 \text{ N/mm}^2$
Paneltwistec, LBS or KonstruX screws in pre-drilled hardwood LVL or FST (ETA-14/0354) and $\rho_a = 730 \text{ kg/m}^3$:
Screw $5 \text{ mm} \leq d \leq 7 \text{ mm}$: $f_{ax,k} = 32 \text{ N/mm}^2$
Screw $8 \text{ mm} \leq d \leq 10 \text{ mm}$: $f_{ax,k} = 25 \text{ N/mm}^2$
LBS screws in non-pre-drilled hardwood LVL or FST (ETA-14/0354) and $\rho_a = 730 \text{ kg/m}^3$:
Screw $d = 8,0 \text{ mm}$: $f_{ax,k} = 30 \text{ N/mm}^2$
 d outer thread diameter [mm]
 ℓ_{ef} point side penetration length of the threaded part according to EN 1995-1-1:2008 [mm]
 α angle between grain and screw axis ($\alpha \geq 30^\circ$ for screws with tip type BS)
 β angle between screw axis and the LVL's wide face ($0^\circ \leq \alpha \leq 90^\circ$)
 ρ_k characteristic density [kg/m^3]
 ρ_a associated density for $f_{ax,k}$ [kg/m^3]

For screws arranged under an angle between screw axis and grain direction of less than 90° , the minimum penetration depth of the screw tip is:

$$\ell_{ef} \geq \min(6 \cdot d / \sin \alpha ; 20 \cdot d)$$

For screws penetrating more than one layer of cross laminated timber, the different layers may be taken into account proportionally.

The axial withdrawal capacity is limited by the head pull-through capacity and the tensile or compressive capacity of the screw.

Head pull-through capacity

The characteristic head pull-through capacity of E.u.r.o.Tec screws shall be calculated according to EN 1995-1-1:2008 from:

$$F_{ax,\alpha,Rk} = n_{ef} \cdot f_{head,k} \cdot d_h^2 \cdot \left(\frac{\rho_k}{350} \right)^{0,8} \quad [N]$$

where:

$F_{ax,\alpha,Rk}$	characteristic head pull-through capacity of the connection at an angle $\alpha \geq 30^\circ$ to the grain [N]
n_{ef}	effective number of screws according to EN 1995-1-1:2008
$f_{head,k}$	characteristic head pull-through parameter [N/mm ²]
d_h	diameter of the screw head [mm]
ρ_k	characteristic density [kg/m ³], for wood-based panels $\rho_k = 380 \text{ kg/m}^3$

Characteristic head pull-through parameter for E.u.r.o.Tec screws with head type FK and FK2 in connections with timber and in connections with wood-based panels with thicknesses above 20 mm:

$$f_{head,k} = 10,0 \text{ N/mm}^2$$

Characteristic head pull-through parameter for E.u.r.o.Tec screws except screws with head type FK and FK2 in connections with timber and in connections with wood-based panels with thicknesses above 20 mm:

$$f_{head,k} = 12,0 \text{ N/mm}^2$$

Characteristic head pull-through parameter for Paneltwistec, LBS or KonstruX screws with a head diameter $d_h \leq 25 \text{ mm}$ in connections with LVL and FST (ETA-14/0354) members with characteristic density $700 \text{ kg/m}^3 \leq \rho_k \leq 750 \text{ kg/m}^3$ with thicknesses of at least 40 mm:

$$f_{head,k} = 47 - 1,5 \cdot d_h \text{ N/mm}^2$$

Characteristic head pull-through parameter for screws in connections with wood-based panels with thicknesses between 12 mm and 20 mm:

$$f_{head,k} = 8 \text{ N/mm}^2$$

Screws in connections with wood-based panels with a thickness below 12 mm (minimum thickness of the wood based panels of $1,2 \cdot d$ with d as outer thread diameter):

$$f_{head,k} = 8 \text{ N/mm}^2$$

limited to $F_{ax,Rk} = 400 \text{ N}$

For “KonstruX” or “LBS” screws, the withdrawal capacity of the thread in the member with the screw head may be taken into account instead of the head pull-through capacity.

The head diameter d_h shall be greater than $1,8 \cdot d_s$, where d_s is the smooth shank or the wire diameter. Otherwise the characteristic head pull-through capacity $F_{ax,\alpha,Rk} = 0$.

The minimum thickness of wood-based panels according to the clause 2.1 must be observed.

In steel-to-timber connections the head pull-through capacity may be disregarded.

Tensile capacity

The characteristic tensile strength $f_{tens,k}$ of E.u.r.o.Tec screws or threaded rods made of carbon steel or martensitic stainless steel 1.4006 except KonstruX or LBS is:

Screw $d = 3,5 \text{ mm}$:	3,8 kN
Screw $d = 4,0 \text{ mm}$:	5,0 kN
Screw $d = 4,5 \text{ mm}$:	6,4 kN
Screw $d = 5,0 \text{ mm}$:	7,9 kN
Screw $d = 6,0 \text{ mm}$:	11 kN
Screw $d = 8,0 \text{ mm}$:	20 kN
Screw $d = 10,0 \text{ mm}$:	28 kN
Screw $d = 12,0 \text{ mm}$:	25 kN
Rod $d = 16,0 \text{ mm}$:	115 kN

The characteristic tensile strength $f_{tens,k}$ of E.u.r.o.Tec KonstruX screws made of carbon steel is:

Screw $d = 6,5 \text{ mm}$:	17 kN
Screw $d = 8,0 \text{ mm}$:	25 kN
Screw $d = 9,0 \text{ mm}$:	30 kN
Screw $d = 10,0 \text{ mm}$:	33 kN
Screw $d = 11,3 \text{ mm}$:	50 kN

The characteristic tensile strength $f_{tens,k}$ of E.u.r.o.Tec LBS screws made of carbon steel is:

Screw $d = 8 \text{ mm}$:	30 kN
----------------------------	-------

The characteristic tensile strength $f_{tens,k}$ of E.u.r.o.Tec screws made of stainless steel (austenitic stainless steel A2 and A4) except KonstruX is:

Screw $d = 3,5 \text{ mm}$:	2,1 kN
Screw $d = 4,0 \text{ mm}$:	2,8 kN
Screw $d = 4,5 \text{ mm}$:	3,5 kN
Screw $d = 4,8 \text{ mm}$:	5,0 kN
Screw $d = 5,0 \text{ mm}$:	4,3 kN
Screw $d = 5,5 \text{ mm}$:	6,0 kN
Screw $d = 6,0 \text{ mm}$:	6,2 kN
Screw $d = 8,0 \text{ mm}$:	11 kN
Screw $d = 10,0 \text{ mm}$:	20 kN

The characteristic tensile strength $f_{tens,k}$ of E.u.r.o.Tec KonstruX screws made of austenitic stainless steel is:

Screw $d = 6,5 \text{ mm}$:	10 kN
Screw $d = 8,0 \text{ mm}$:	14 kN
Screw $d = 10,0 \text{ mm}$:	20 kN

For screws used in combination with steel plates, the tear-off capacity of the screw head should be greater than the tensile strength of the screw.

Compressive capacity

The characteristic buckling capacity $F_{ki,Rk}$ of E.u.r.o.Tec “KonstruX” or “LBS” screws or “BRUTUS” threaded rods embedded in timber shall be calculated from:

$$F_{ki,Rk} = \kappa_c \cdot N_{pl,k} \quad [N]$$

where

$$\kappa_c = \begin{cases} 1 & \text{for } \bar{\lambda}_k \leq 0,2 \\ \frac{1}{k + \sqrt{k^2 - \bar{\lambda}_k^2}} & \text{for } \bar{\lambda}_k > 0,2 \end{cases}$$

$$k = 0,5 \cdot \left[1 + 0,49 \cdot (\bar{\lambda}_k - 0,2) + \bar{\lambda}_k^2 \right]$$

The relative slenderness ratio shall be calculated from:

$$\bar{\lambda}_k = \sqrt{\frac{N_{pl,k}}{N_{ki,k}}}$$

Where

$$N_{pl,k} = \pi \cdot \frac{d_1^2}{4} \cdot f_{y,k} \quad [N]$$

is the characteristic value for the axial capacity in case of plastic analysis referred to the inner thread cross section.

Characteristic yield strength:

$f_{y,k} = 1000$ [N/mm²] for KonstruX or LBS screws made of carbon steel or stainless steel hardened (martensitic stainless steel)

$f_{y,k} = 750$ [N/mm²] for BRUTUS threaded rods

$f_{y,k} = 500$ [N/mm²] for KonstruX screws made of stainless steel unhardened (austenitic stainless steel A2 and A4)

Characteristic ideal elastic buckling load:

$$N_{ki,k} = \sqrt{c_h \cdot E_s \cdot I_s} \quad [N]$$

Elastic foundation of the screw:

$$c_h = (0,19 + 0,012 \cdot d) \cdot \rho_k \cdot \left(\frac{\alpha}{180^\circ} + 0,5 \right) \quad [N/mm^2]$$

Modulus of elasticity:

$$E_s = 205000 \quad [N/mm^2]$$

Second moment of area:

$$I_s = \frac{\pi}{64} \cdot d_1^4 \quad [mm^4]$$

d_1 = inner thread diameter [mm]

α = angle between screw axis and grain direction [°]

Note: When determining design values of the compressive capacity it should be considered that $f_{ax,d}$ is to be calculated using k_{mod} and γ_M for timber according to EN 1995 while $N_{pl,d}$ is calculated using $\gamma_{M,0}$ for steel according to EN 1993.

Mechanically jointed beams

“KonstruX” or “LBS” screws with a full thread or “BRUTUS” threaded rods may be used for connections in

structural members which are composed of several parts in mechanically jointed beams or columns.

The axial slip modulus K_{ser} of a screw or threaded rod with a full thread for the serviceability limit state should be taken independent of angle α to the grain as:

$C = K_{ser} = 25 \cdot d \cdot \ell_{ef}$ [N/mm] for screws in softwood

$C = K_{ser} = 30 \cdot d \cdot \ell_{ef}$ [N/mm] for screws in hardwood

$C = K_{ser} = 250 \cdot \ell_{ef}$ [N/mm] for threaded rods

Where

d outer thread diameter [mm]

ℓ_{ef} penetration length in the structural member [mm] (see Annex B)

Combined laterally and axially loaded screws

For screwed connections subjected to a combination of axial and lateral load, the following expression should be satisfied:

$$\left(\frac{F_{ax,Ed}}{F_{ax,Rd}} \right)^2 + \left(\frac{F_{la,Ed}}{F_{la,Rd}} \right)^2 \leq 1$$

where

$F_{ax,Ed}$ axial design load of the screw

$F_{la,Ed}$ lateral design load of the screw

$F_{ax,Rd}$ design load-carrying capacity of an axially loaded screw

$F_{la,Rd}$ design load-carrying capacity of a laterally loaded screw.

3.5 Aspects related to the performance of the product

3.5.1 Corrosion protection in service class 1, 2 and 3.

The E.u.r.o. Tec screws with nominal diameters of 3,5 mm to 16,0 mm are produced from carbon wire. Screws made from carbon steel are electrogalvanised or otherwise coated appropriate for the expected working life and service class. The mean thickness of the zinc coating is 5µm.

Screws with nominal diameters of 3,5 mm to 8,0 mm are produced from hardened stainless steel no. 1.4006 or unhardened stainless steel no. 1.4301, 1.4401, 1.4567 and 1.4578.

3.6 General aspects related to the intended use of the product

The screws or threaded rods are manufactured in accordance with the provisions of the European Technical Assessment using the automated manufacturing process and laid down in the technical documentation.

The installation shall be carried out in accordance with Eurocode 5 or an appropriate national code unless otherwise is defined in the following. Instructions from E.u.r.o.Tec GmbH should be considered for installation.

The screws or threaded rods are used for connections in load bearing timber structures between members of solid timber (softwood), glued laminated timber, cross-laminated timber, and laminated veneer lumber, similar glued members, wood-based panels or steel members.

The screws or threaded rods may be used for connections in load bearing timber structures with structural members according to an associated ETA, if according to the associated ETA of the structural member a connection in load bearing timber structures with screws according to a ETA is allowed.

E.u.r.o.Tec fully threaded „KonstruX” or “LBS” screws or threaded rods are also used as tensile or compressive reinforcement perpendicular to the grain.

Furthermore the screws with diameters of at least 6 mm may also be used for the fixing of insulation on top of rafters.

A minimum of two screws or threaded rods should be used for connections in load bearing timber structures.

Wood-based panels and steel plates should only be arranged on the side of the screw head. The minimum thickness of wood-based panels should be $1,2 \cdot d$. Furthermore the minimum thickness for following wood-based panels should be:

- Plywood, Fibreboards: 6 mm
- Particleboards, OSB, Cement Particleboards: 8 mm
- Solid wood panels: 12 mm

For structural members according to ETA's the terms of the ETA's must be considered.

If screws with an outer thread diameter $d \geq 8$ mm are used in load bearing timber structures, the structural solid or glued laminated timber, laminated veneer lumber and similar glued members must be from spruce, pine or fir. This does not apply for screws or threaded rods in pre-drilled holes or for screws with tip type BS or rBS DAG in non-pre-drilled holes.

The minimum angle between the screw axis of screws with tip type BS or BRUTUS threaded rods and the grain direction is $\alpha = 30^\circ$. For other screws: $0^\circ \leq \alpha \leq 90^\circ$.

The screws shall be driven into the wood with or without pre-drilling. The maximum pre-drilling diameter is the inner thread diameter for the length of the threaded part and the smooth shank diameter for the depth of the smooth shank.

The drill hole diameters are:

Outer thread diameter [mm]	Drill hole diameter [mm]	
	Softwood	Beech LVL or FST
4,0	2,5	-
4,5	2,5	-
5,0	3,0	3,5
6,0	4,0	4,5
6,5	4,0	5,0
8,0	5,0	6,0
10,0	6,0	8,0
12,0	7,0	-

The threaded rods shall be driven into softwood after pre-drilling with the following diameter:

BRUTUS threaded rod 16 mm: Pre-drilling diameter 13 mm

BRUTUS threaded rod shall only be driven into pre-drilled holes.

The hole diameter in steel members must be predrilled with a suitable diameter.

Only the equipment prescribed by E.u.r.o.Tec GmbH shall be used for driving the screws.

In connections with screws with countersunk head according to Annex A the head must be flush with the surface of the connected structural member. A deeper countersink is not allowed.

For structural timber members, minimum spacing and distances for screws or threaded rods in predrilled holes are given in Eurocode 5 clause 8.3.1.2 and table 8.2 as for nails in predrilled holes. Here, the outer thread diameter d must be considered.

For screws in non-predrilled holes, minimum spacing and distances are given in Eurocode 5 clause 8.3.1.2 and table 8.2 as for nails in non-predrilled holes.

For Douglas fir members minimum spacing and distances parallel to the grain shall be increased by 50%.

Minimum distances from loaded or unloaded ends must be $15 \cdot d$ for screws in non-predrilled holes with outer thread diameter $d \geq 8$ mm and timber thickness $t < 5 \cdot d$.

Minimum distances from the unloaded edge perpendicular to the grain may be reduced to $3 \cdot d$ also for timber thickness $t < 5 \cdot d$, if the spacing parallel to the grain and the end distance is at least $25 \cdot d$.

Minimum distances and spacing for exclusively axially loaded screws in non-predrilled holes in members with a minimum thickness $t = 10 \cdot d$ and a minimum width of $8 \cdot d$ or 60 mm, whichever is the greater, may be taken as:

Spacing a_1 parallel to the grain $a_1 = 5 \cdot d$

Spacing a_2 perpendicular to the grain $a_2 = 5 \cdot d$
 Distance $a_{1,c}$ from centre of the screw-part in
 timber to the end grain $a_{1,c} = 10 \cdot d$
 Distance $a_{2,c}$ from centre of the screw-part in
 timber to the edge $a_{2,c} = 4 \cdot d$

Spacing a_2 perpendicular to the grain may be reduced from $5 \cdot d$ to $2,5 \cdot d$, if the condition $a_1 \cdot a_2 \geq 25 \cdot d^2$ is fulfilled.

Minimum distances and spacing for 8 mm “LBS” screws in non-predrilled holes in Beech LVL or FST members with a minimum thickness $t = 14 \cdot d$ and a minimum width of $14 \cdot d$ may be taken as:

Spacing a_1 parallel to the grain $a_1 = 15 \cdot d$
 Spacing a_2 perpendicular to the grain $a_2 = 7 \cdot d$
 Loaded end distance $a_{3,t}$ $a_{3,t} = 20 \cdot d$
 Unloaded end distance $a_{3,c}$ $a_{3,t} = 15 \cdot d$
 Loaded edge distance $a_{4,t}$ $a_{3,t} = 10 \cdot d$
 Unloaded edge distance $a_{4,c}$ $a_{3,t} = 7 \cdot d$

Minimum distances and spacing for exclusively axially loaded screws in predrilled holes or for screws with tip type BS or rBS DAG in non-predrilled holes in members with a minimum thickness $t = 10 \cdot d$ and a minimum width of $8 \cdot d$ or 60 mm, whichever is the greater, may be taken as:

Spacing a_1 parallel to the grain $a_1 = 5 \cdot d$
 Spacing a_2 perpendicular to the grain $a_2 = 5 \cdot d$
 Distance $a_{1,c}$ from centre of the screw-part in
 timber to the end grain $a_{1,c} = 5 \cdot d$
 Distance $a_{2,c}$ from centre of the screw-part in
 timber to the edge $a_{2,c} = 3 \cdot d$

Spacing a_2 perpendicular to the grain may be reduced from $5 \cdot d$ to $2,5 \cdot d$, if the condition $a_1 \cdot a_2 \geq 25 \cdot d^2$ is fulfilled.

For a crossed screw couple the minimum spacing between the crossing screws is $1,5 \cdot d$.

Minimum thickness for structural members is $t = 24$ mm for screws with outer thread diameter $d < 8$ mm, $t = 30$ mm for screws with outer thread diameter $d = 8$ mm, and $t = 40$ mm for screws with outer thread diameter $d = 10$ mm.

Unless specified otherwise in the technical specification (ETA or hEN) of cross laminated timber, minimum distances and spacing for screws in the wide face of cross laminated timber members with a minimum thickness $t = 10 \cdot d$ may be taken as (see Annex B):

Spacing a_1 parallel to the grain $a_1 = 4 \cdot d$
 Spacing a_2 perpendicular to the grain $a_2 = 2,5 \cdot d$
 Distance $a_{3,c}$ from centre of the screw-part in
 timber to the unloaded end grain $a_{3,c} = 6 \cdot d$
 Distance $a_{3,t}$ from centre of the screw-part in
 timber to the loaded end grain $a_{3,t} = 6 \cdot d$
 Distance $a_{4,c}$ from centre of the screw-part in

timber to the unloaded edge $a_{4,c} = 2,5 \cdot d$
 Distance $a_{4,t}$ from centre of the screw-part in
 timber to the loaded edge $a_{4,t} = 6 \cdot d$

Unless specified otherwise in the technical specification (ETA or hEN) of cross laminated timber, minimum distances and spacing for screws in the edge surface of cross laminated timber members with a minimum thickness $t = 10 \cdot d$ and a minimum penetration depth perpendicular to the edge surface of $10 \cdot d$ may be taken as (see Annex B):

Spacing a_1 parallel to the CLT plane $a_1 = 10 \cdot d$
 Spacing a_2 perpendicular to the CLT plane $a_2 = 4 \cdot d$
 Distance $a_{3,c}$ from centre of the screw-part in
 timber to the unloaded end $a_{3,c} = 7 \cdot d$
 Distance $a_{3,t}$ from centre of the screw-part in
 timber to the loaded end $a_{3,t} = 12 \cdot d$
 Distance $a_{4,c}$ from centre of the screw-part in
 timber to the unloaded edge $a_{4,c} = 3 \cdot d$
 Distance $a_{4,t}$ from centre of the screw-part in
 timber to the loaded edge $a_{4,t} = 6 \cdot d$

4 Attestation and verification of constancy of performance (AVCP)

4.1 AVCP system

According to the decision 97/176/EC of the European Commission¹, as amended, the system(s) of assessment and verification of constancy of performance (see Annex V to Regulation (EU) No 305/2011) is 3.

5 Technical details necessary for the implementation of the AVCP system, as foreseen in the applicable EAD

Technical details necessary for the implementation of the AVCP system are laid down in the control plan deposited at ETA-Danmark prior to CE marking.

Issued in Copenhagen on 2022-08-25 by



Thomas Bruun
Managing Director, ETA-Danmark

Annex A
KonstruX HF
carbon steel¹

nominal size	Ø6,5	Ø8,0	Ø9,0	Ø10,0	Ø11,3
d	6,5	8,0	9,0	10,0	11,3
di	4,5	5,2	6,4	6,0	8,0
dh	8,0	10,0	10,0	13,0	13,0
hh	5,5	6,5	6,5	6,5	6,5
p	4,9	5,2	5,6	5,6	5,6
dt	4,9	6,0	6,4	6,5	8,3
t	7,0	8,0	8,0	11,5	12,0
dh2	12,0	14,5	14,5	17,8	18,5
hh2	5,7	7,4	7,0	8,7	7,0
dh3	-	22,0	22,0	25,0	22,0
dm	-	5,6	-	7,0	-
hm	-	4,5	-	4,0	-
dm2	-	6,2	-	7,2	-
SW	-	SW13	-	-	-
SW2	SW8	SW10	SW10	SW13	SW13

L min	39	48	51	61	65
L max	195	480	600	600	1000

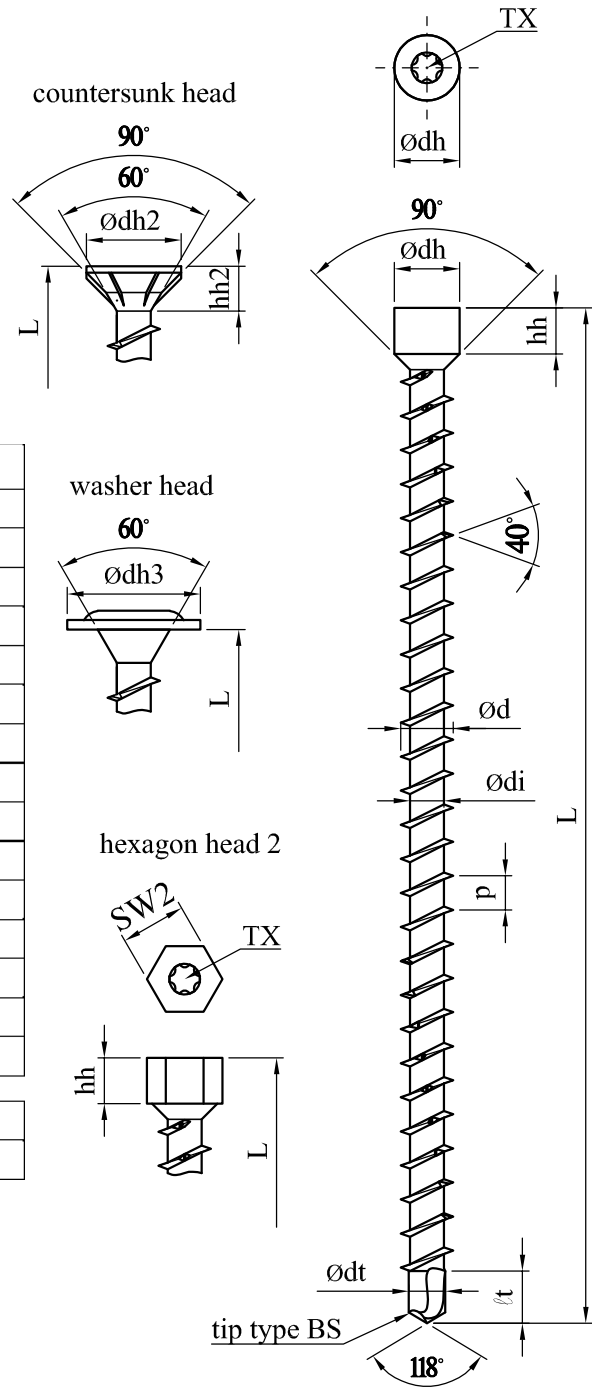

thread-free part
acceptable for:
L < 300 mm with ≈ 3 mm
L ≥ 300 mm with ≈ 3x p

tip type 17M

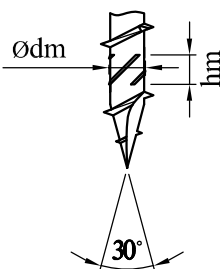

tip type 17

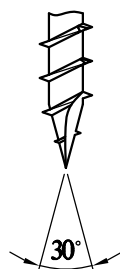

tip type AG

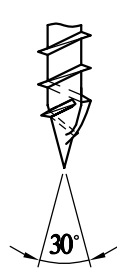

tip type DAG

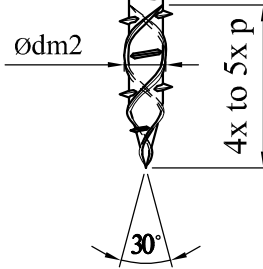

¹) Material specification held on file by ETA Danmark.

²) Tolerances according to EAD 130118-00-0603.

KonstruX ST
carbon steel¹

nominal size	Ø6,5	Ø8,0	Ø10,0
d	6,5	8,0	10,0
di	4,5	5,2	5,9
dh	8,0	10,0	13,0
hh	5,5	6,5	6,5
p	3,0	3,8	4,6
dt	4,3	4,9	5,5
t	4,0	5,0	6,0
dh2	12,0	14,5	17,8
hh2	5,7	7,4	8,7
dh3	-	22,0	25,0
dm	4,9	5,8	6,5
SW	-	SW13	-
SW2	SW8	SW10	SW13

L min	36	44	55
L max	195	580	600

All dimensions in mm.²⁾

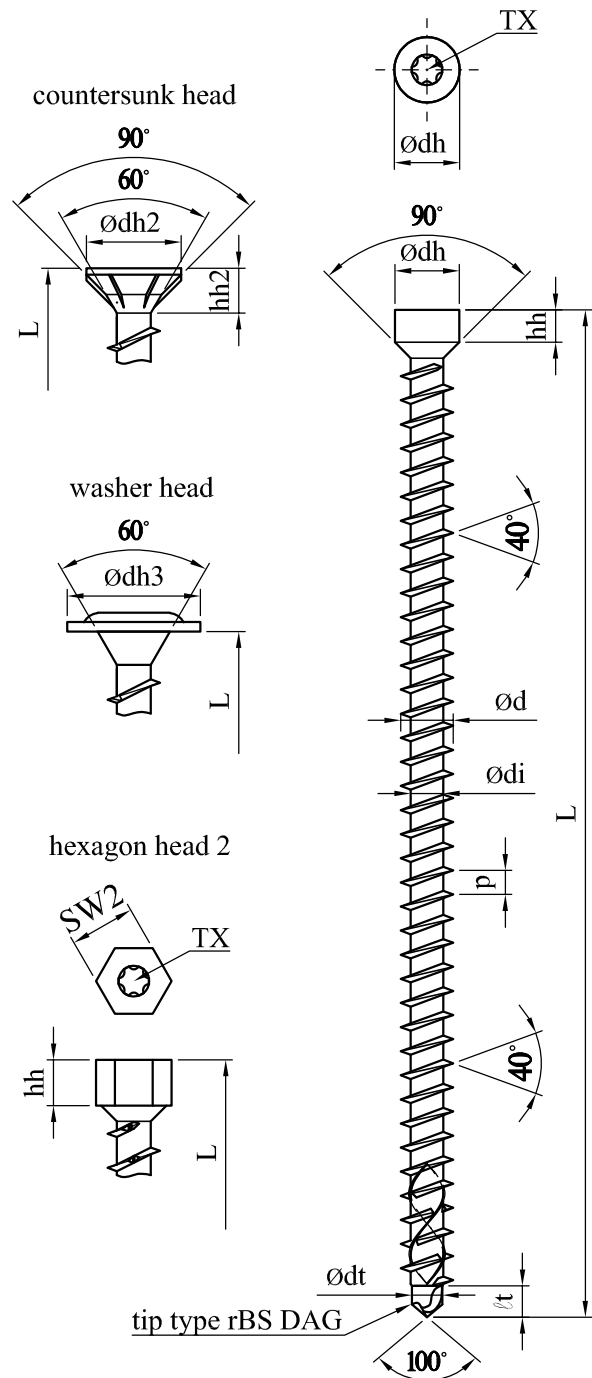

thread-free part
acceptable for:
L < 300 mm with ≈ 3 mm
L ≥ 300 mm with ≈ 3x p

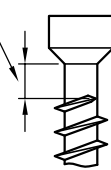
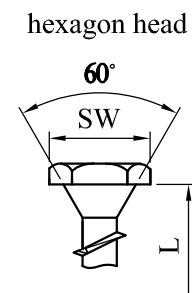
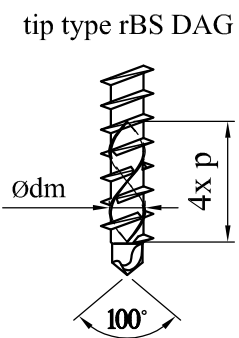

¹⁾ Material specification held on file by ETA Danmark.

²⁾ Tolerances according to EAD 130118-00-0603.

KonstruX ST V4A
stainless steel unhardened¹

nominal size	Ø6,5	Ø8,0
d	6,5	8,0
di	4,5	5,2
dh	8,0	10,0
hh	5,5	6,5
p	3,0	3,8
dt	4,3	4,9
t	4,0	5,0
dh2	12,0	14,5
hh2	5,7	7,4
dh3	-	22,0
dm	4,9	5,8
SW	-	SW13
SW2	SW8	SW10

L min	36	44
L max	195	400

All dimensions in mm.²⁾

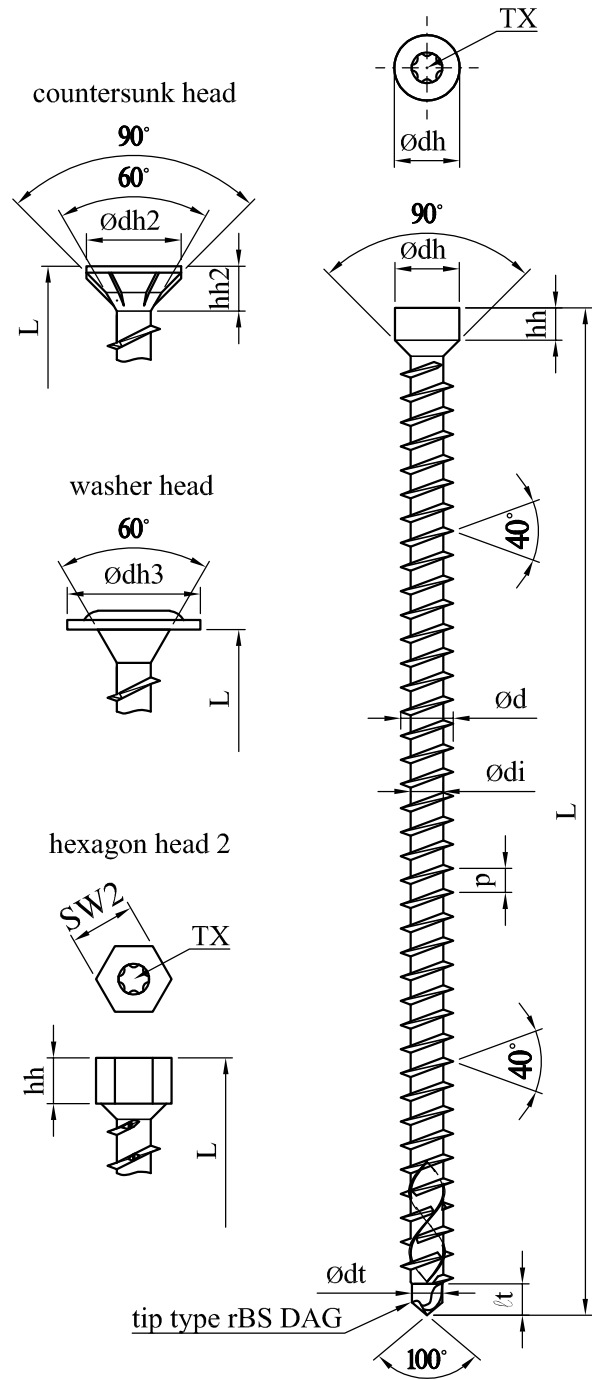

thread-free part
acceptable for:
L < 300 mm with ≈ 3 mm
L ≥ 300 mm with ≈ 3x p

tip type rBS DAG

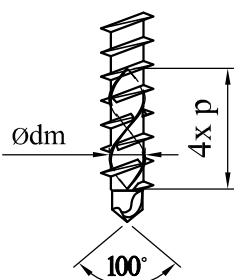

hexagon head

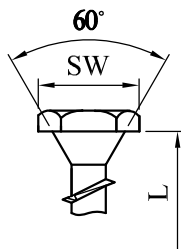

¹⁾ Material specification held on file by ETA Denmark.

²⁾ Tolerances according to EAD 130118-00-0603.

KonstruX V4A
stainless steel unhardened¹

nominal size	Ø10,0
d	10,0
di	6,0
dh	13,0
hh	6,5
p	4,6
dh2	17,8
hh2	8,7
dh3	25,0
SW2	SW13

L min	49
L max	400

All dimensions in mm.²⁾

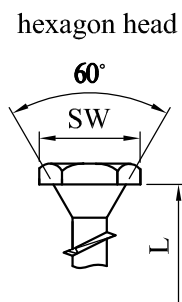
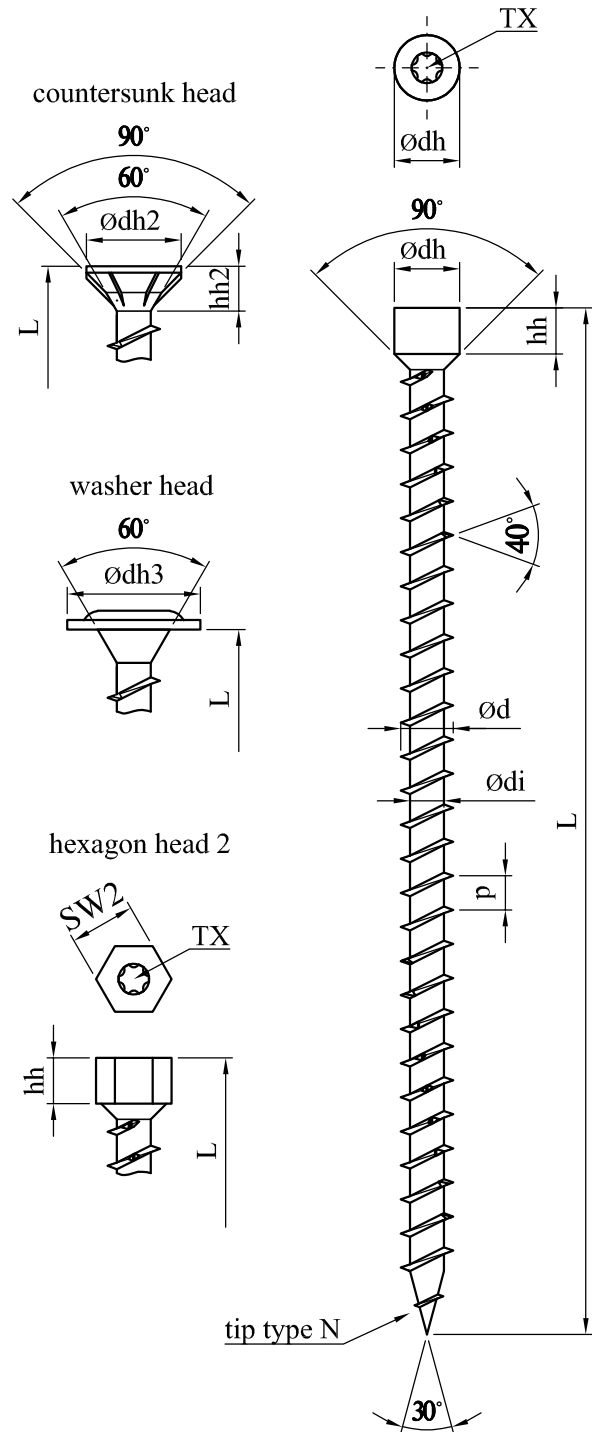

thread-free part
acceptable for:
 $L < 300$ mm with ≈ 3 mm
 $L \geq 300$ mm with $\approx 3 \times p$

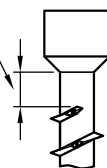

¹⁾ Material specification held on file by ETA Danmark.

²⁾ Tolerances according to EAD 130118-00-0603.

Paneltwistec countersunk head 90°
 carbon steel¹
 stainless steel hardened¹

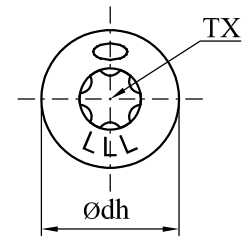

nominal size	Ø3,5	Ø4,0	Ø4,5	Ø5,0	Ø6,0	Ø8,0	Ø10,0	Ø12,0
d	3,5	4,0	4,5	5,0	6,0	8,0	10,0	12,0
di	2,1	2,5	2,7	3,3	4,0	5,3	6,3	7,1
dh	7,0	8,0	9,0	10,0	12,0	14,5	17,8	20,0
hh	3,5	4,0	4,4	4,8	5,7	7,0	8,7	9,3
p	2,25	2,5	2,8	3,1	4,9	5,6	6,6	6,6
ds	2,3	2,8	3,0	3,6	4,3	5,7	6,9	8,1
dm	2,7	2,9	3,4	3,9	4,8	6,5	7,9	9,6
dc	3,5	4,0	5,4	6,0	7,2	8,0	10,0	-
hhc	3,8	4,2	4,7	5,3	5,6	7,3	8,3	-
dh2	-	5,5	7,0	8,5	11,5	-	-	-
dm2	2,45	2,8	3,2	3,8	4,6	6,2	7,2	-
lg min	14	16	18	20	24	32	40	48
lg max	30	48	48	70	70	100	100	120
L min	18	20	23	25	30	39	49	57
L max	50	80	80	120	300	600	600	400

All dimensions in mm.²⁾

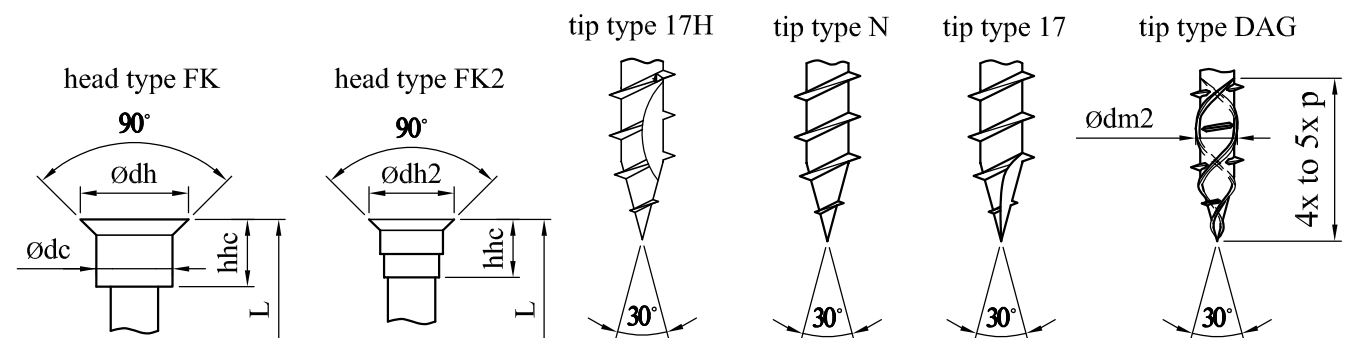
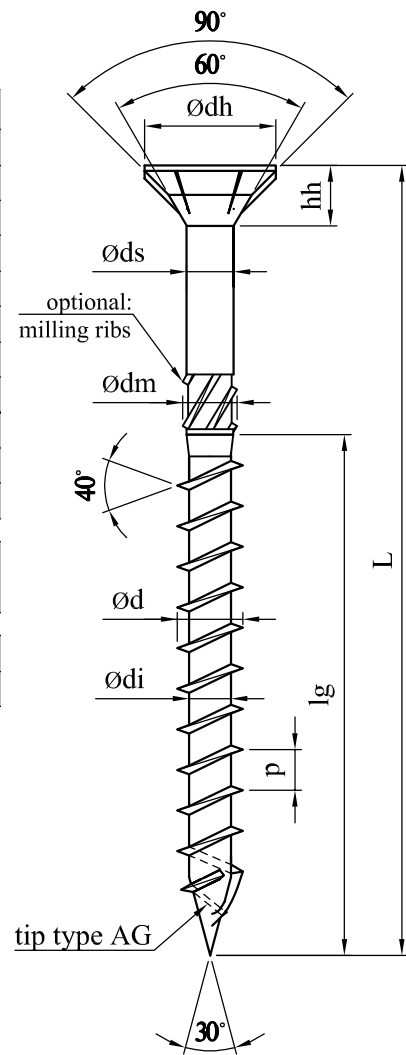

¹⁾ Material specification held on file by ETA Danmark.

²⁾ Tolerances according to EAD 130118-00-0603.

Paneltwistec countersunk head 60°
 carbon steel¹
 stainless steel hardened¹

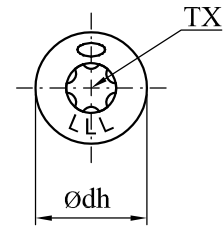

nominal size	Ø3,5	Ø4,0	Ø4,5	Ø5,0	Ø6,0	Ø8,0	Ø10,0
d	3,5	4,0	4,5	5,0	6,0	8,0	10,0
di	2,1	2,5	2,7	3,3	4,0	5,3	6,3
dh	5,0	6,0	7,0	7,5	9,5*	11,0	13,0
hh	1,9	3,6	4,3	4,8	5,8	6,3	8,2
p	2,25	2,5	2,8	3,1	4,9	5,6	6,6
ds	2,3	2,8	3,0	3,6	4,3	5,7	6,9
dm	2,7	2,9	3,4	3,9	4,8	6,5	7,9
dt	2,0	2,3	2,5	2,9	3,4	5,3	6,3
t	3,4	3,9	4,4	4,9	4,9	5,1	6,1
dc	3,5	4,0	5,4	6,0	7,2	8,0	10,0
hhc	3,8	4,2	4,7	5,3	5,6	7,3	8,3
dh2	-	5,5	7,0	8,5	11,5	-	-
dm2	2,45	2,8	3,2	3,8	4,6	6,2	7,2

lg min	14	16	18	20	24	32	40
lg max	30	48	48	70	70	100	100

L min	18	20	23	25	30	39	48
L max	50	80	80	120	300	600	600

All dimensions in mm.²⁾
 *dh= 7,5 mm standard version
 dh= 9,5 mm special version

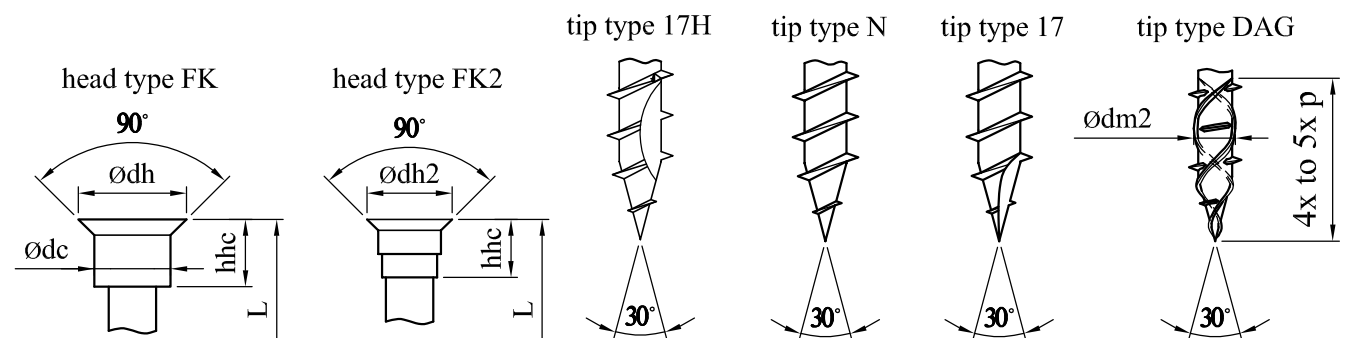
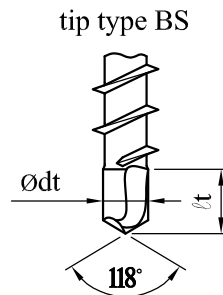
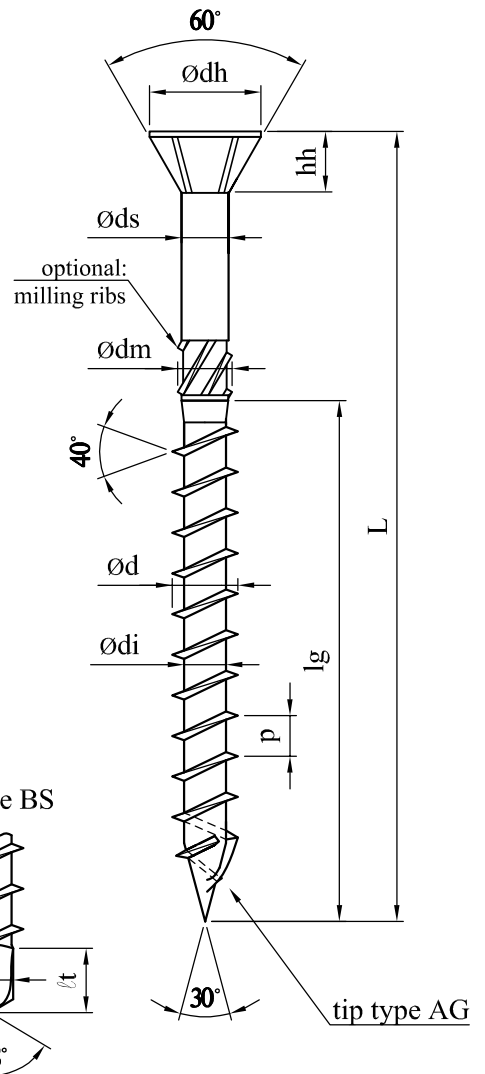

¹⁾ Material specification held on file by ETA Danmark.

²⁾ Tolerances according to EAD 130118-00-0603.

Paneltwistec washer head
 carbon steel¹
 stainless steel hardened¹

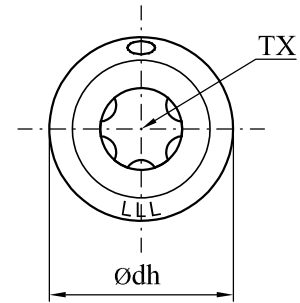

nominal size	Ø3,5	Ø4,0	Ø4,5	Ø5,0	Ø6,0	Ø8,0	Ø10,0
d	3,5	4,0	4,5	5,0	6,0	8,0	10,0
di	2,1	2,5	2,7	3,3	4,0	5,3	6,3
dh	8,0	10,0	11,0	12,0	14,0	22,0	25,0
dc	4,3	4,8	5,5	6,0	7,0	10,0	12,0
p	2,25	2,5	2,8	3,1	4,9	5,6	6,6
ds	2,3	2,8	3,0	3,6	4,3	5,7	6,9
dm	2,7	2,9	3,4	3,9	4,8	6,5	7,9
dm2	2,45	2,8	3,2	3,8	4,6	6,2	7,2
lg min	14	16	18	20	24	32	40
lg max	30	48	48	70	70	100	100
L min	15	17	19	21	25	33	41
L max	50	80	80	120	300	600	600

All dimensions in mm.²⁾

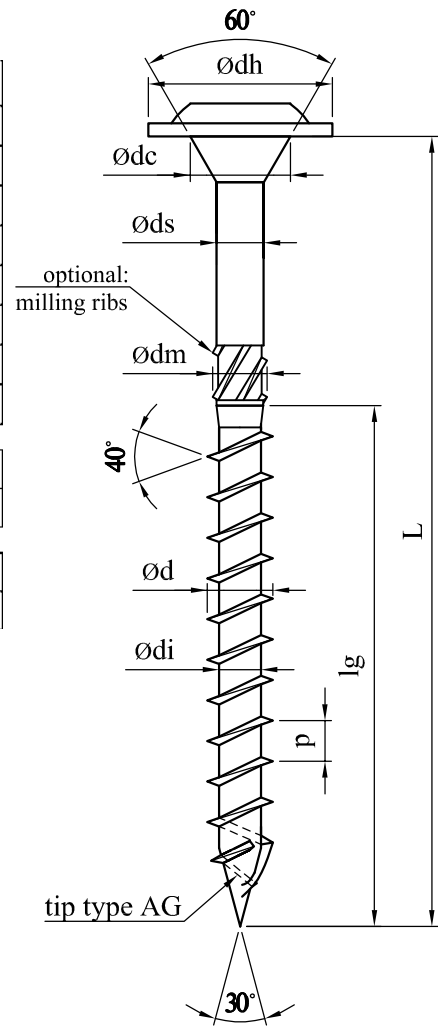

tip type 17H

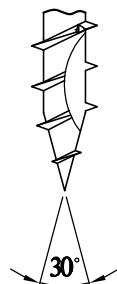

tip type N

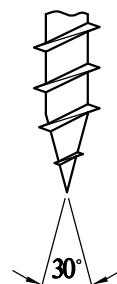

tip type 17



tip type DAG

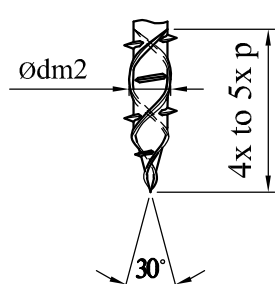

¹⁾ Material specification held on file by ETA Danmark.

²⁾ Tolerances according to EAD 130118-00-0603.

Paneltwistec small washer head
 carbon steel¹
 stainless steel hardened¹

nominal size	Ø8,0
d	8,0
di	5,3
dh	18,0
dc	8,0
p	5,6
ds	5,8
dm	6,7
dm2	6,2

lg min	32
lg max	100

l. min	33
L max	600

All dimensions in mm.²⁾

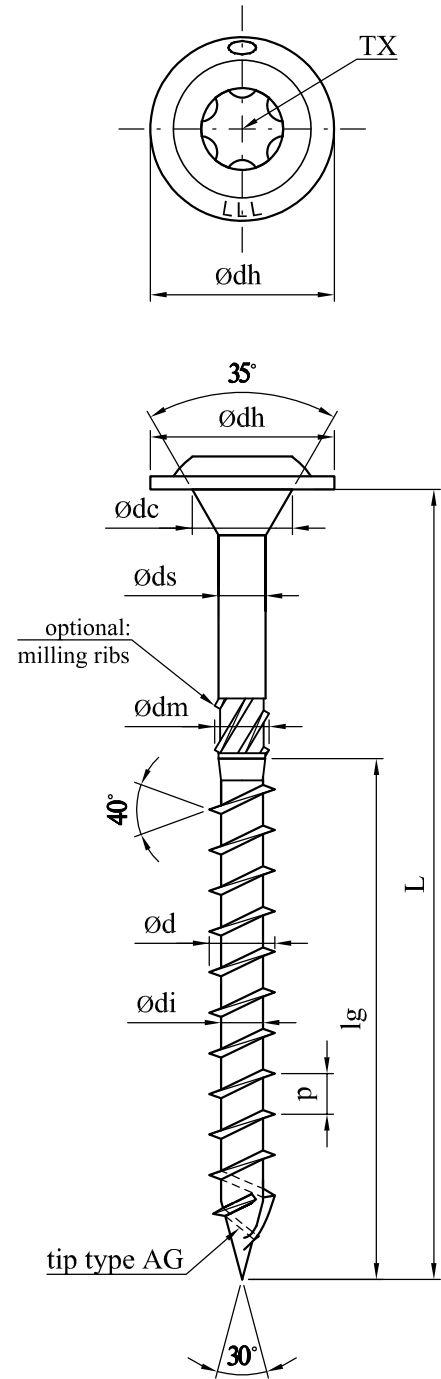

tip type 17H

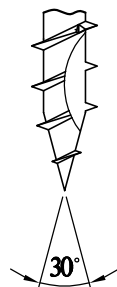

tip type N

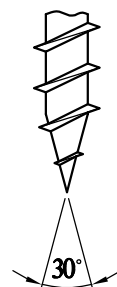

tip type 17



tip type DAG

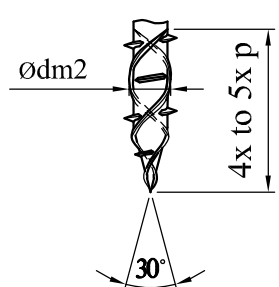

¹⁾ Material specification held on file by ETA Danmark.

²⁾ Tolerances according to EAD 130118-00-0603.

Paneltwistec V2A 8 mm
stainless steel unhardened¹

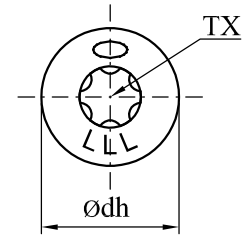

nominal size	Ø8.0
d	8,0
di	5,3
dh	14,5
hh	7,0
p	5,6
ds	5,7
dm	6,5
dc	8,0
hhc	7,3
dh2	16,0

lg min	32
lg max	80

L min	39
L max	140

All dimensions in mm.²⁾

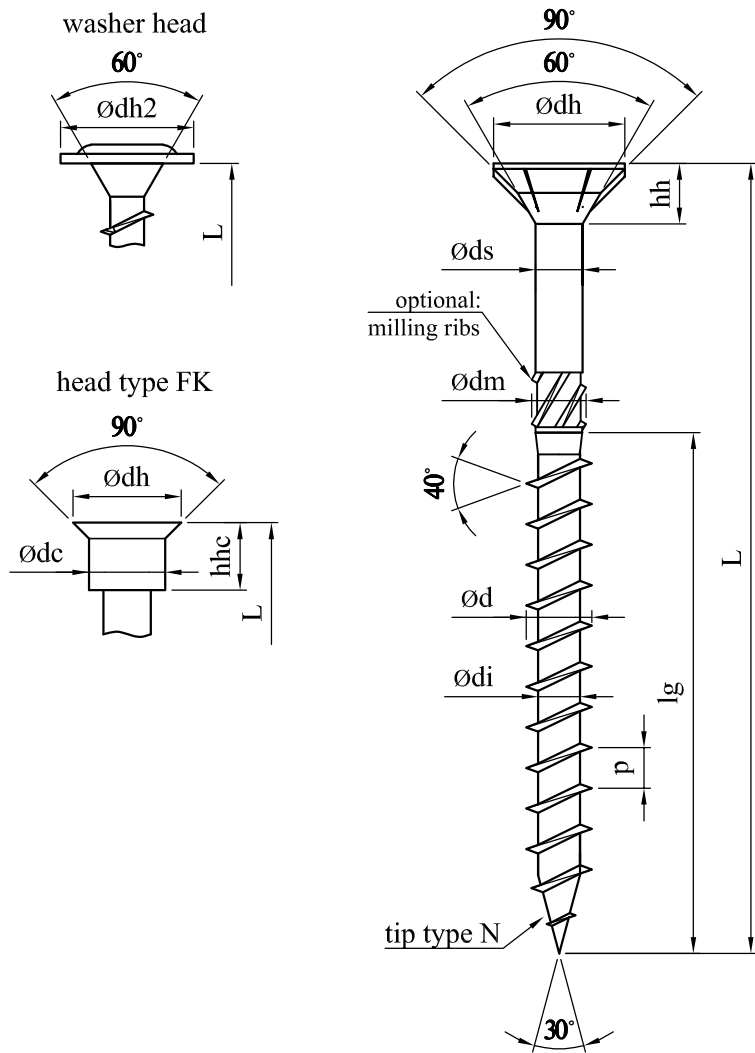

¹⁾ Material specification held on file by ETA Danmark.

²⁾ Tolerances according to EAD 130118-00-0603.

Duratec
carbon steel¹

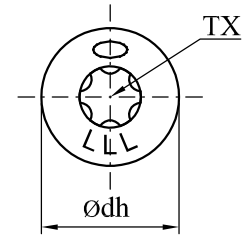

nominal size	Ø3,5	Ø4,0	Ø4,5	Ø5,0	Ø6,0	Ø8,0	Ø10,0
d	3,5	4,0	4,5	5,0	6,0	8,0	10,0
di	2,1	2,5	2,7	3,3	4,0	5,3	6,3
dh	7,0	8,0	9,0	10,0	12,0	14,5	17,8
hh	3,5	4,0	4,4	4,8	5,7	7,0	8,7
p	2,24	2,5	2,8	3,1	4,9	5,6	6,6
ds	2,3	2,8	3,0	3,6	4,3	5,7	6,9
dm	2,7	2,9	3,4	3,9	4,8	6,5	7,9
dc	3,5	4,0	5,4	6,0	7,2	8,0	10,0
hhc	3,8	4,2	4,7	5,3	5,6	7,3	8,3
dh2	-	5,5	7,0	8,5	11,5	-	-
dh3	8,0	10,0	11,0	12,0	14,0	22,0	25,0
dd	2,5	2,9	3,2	3,7	4,6	6,2	7,3

lg min	14	16	18	20	24	32	40
lg max	30	48	48	70	70	80	90

L min	18	20	23	25	30	39	49
L max	50	80	80	120	300	600	600

All dimensions in mm.²⁾

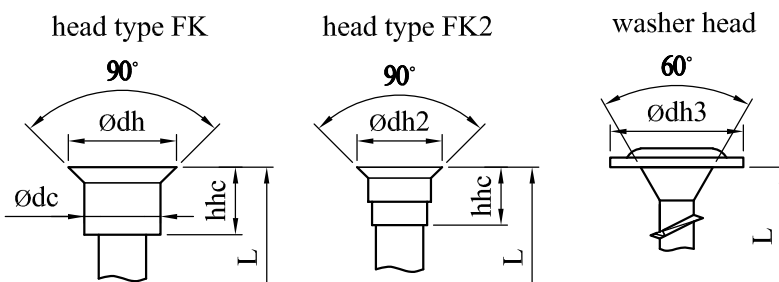
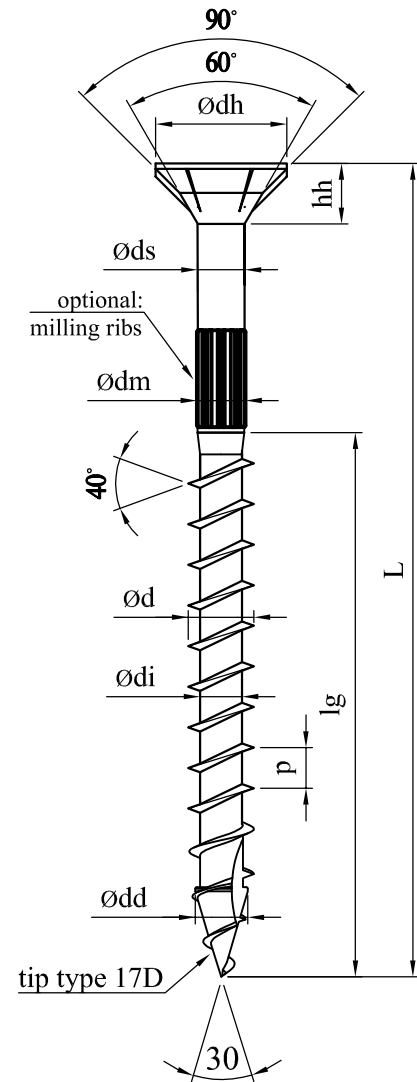

¹⁾ Material specification held on file by ETA Danmark.

²⁾ Tolerances according to EAD 130118-00-0603.

Topduo
carbon steel¹
stainless steel hardened¹

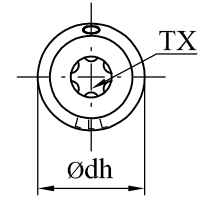

countersunk head

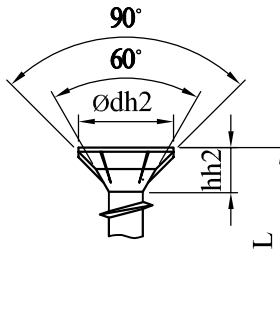

head type ZK

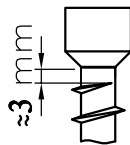
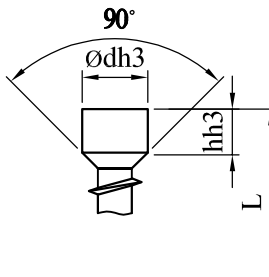

head type FK

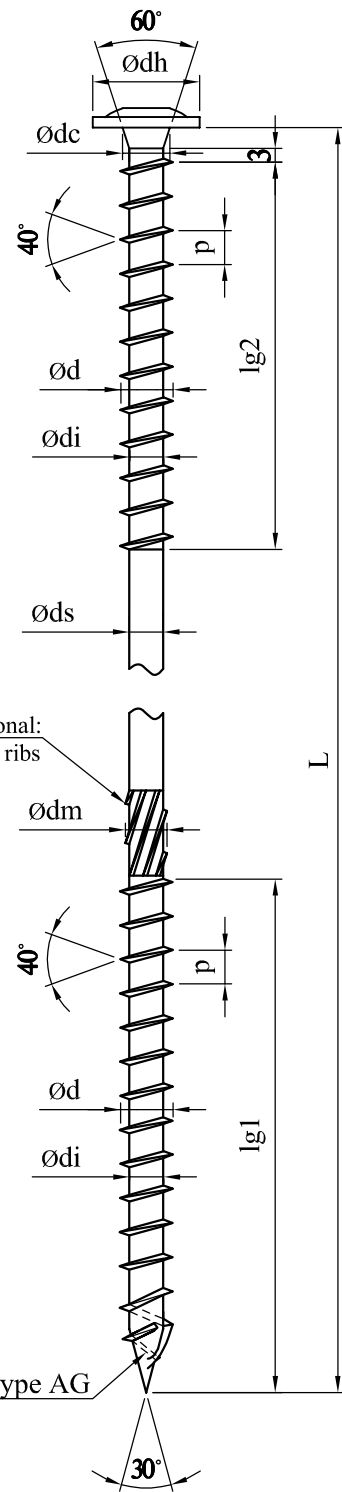
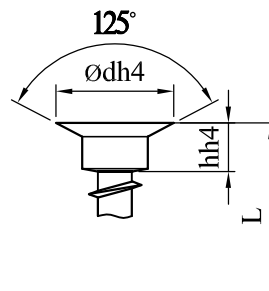

nominal size	Ø8,0
d	8,0
di	5,3
dh	16,0
dc	8,0
p	5,6
ds	5,8
dm	6,5
dh2	14,5
hh2	7,4
dh3	10,0
hh3	6,5
dh4	18,3
hh4	7,3
dm2	6,20

lg1 min	32
lg1 max	100

lg2 min	32
lg2 max	60

L min	94
L max	472

All dimensions in mm.²⁾

tip type N

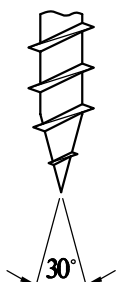

tip type 17



tip type DAG

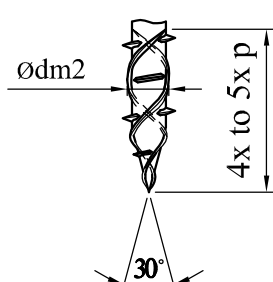

tip type 17H

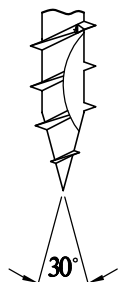

tip type AG



¹⁾ Material specification held on file by ETA Danmark.

²⁾ Tolerances according to EAD 130118-00-0603.

Terrassotec, S-L-SP, SP FK
 carbon steel¹
 stainless steel hardened¹

Terrassotec, S-L-SP FK					
nominal size	Ø3,5	Ø4,0	Ø4,5	Ø5,0	Ø6,0
d	3,5	4,0	4,5	5,0	6,0
di	2,1	2,5	2,7	3,3	4,0
dh	5,0	5,5	7,0	8,5	12,0
dc	3,5	4,0	5,4	6,0	7,2
hh	2,0	4,3	4,8	5,4	5,6
β	90°	90°	90°	90°	90°
p	2,25	2,5	2,8	3,1	3,6
ds	2,3	2,8	3,0	3,6	4,4
dh2	-	4,2	4,7	5,3	5,6
hh2	-	5,5	7,0	8,5	11,5
dm	2,9	3,4	3,9	4,0	5,0
dm2	2,45	2,8	3,2	3,8	4,6
lg min	14	16	18	20	24
lg max	30	48	48	70	70
L min	16	22	25	29	36
L max	50	80	80	120	300

SP FK		
Ø6,0	Ø8,0	Ø10,0
6,0	8,0	10,0
4,0	5,3	6,3
13,5	18,0	21,0
6,5	10,3	11,0
6,0	7,2	8,3
125°	125°	125°
4,9	5,6	6,6
4,3	5,7	6,9
-	-	-
-	-	-
3,9	4,0	5,0
4,6	6,2	7,2
24	32	40
70	100	100
30	39	48
300	600	600

All dimensions in mm.²⁾

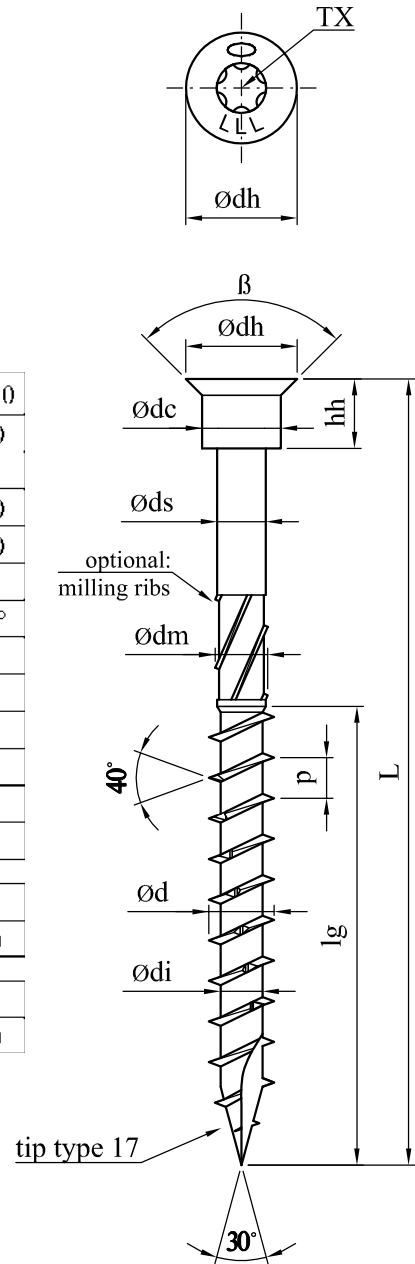

head type FK2

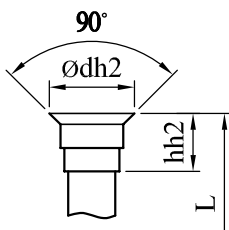

tip type 17H

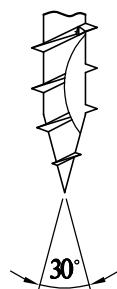

tip type N

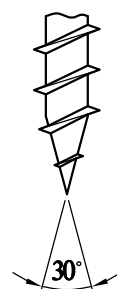

tip type AG



tip type DAG

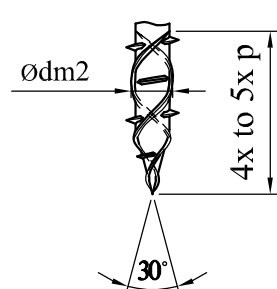

¹⁾ Material specification held on file by ETA Danmark.

²⁾ Tolerances according to EAD 130118-00-0603.

Speedo
carbon steel¹

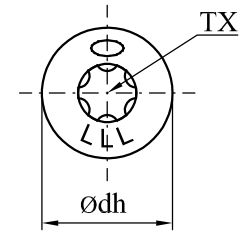

nominal size	Ø3,5	Ø4,0	Ø4,5	Ø5,0	Ø6,0	Ø8,0	Ø10,0
d	3,5	4,0	4,5	5,0	6,0	8,0	10,0
di	2,1	2,5	2,6	3,2	3,9	5,4	6,3
dh	7,0	8,0	9,0	10,0	12,0	14,5	17,8
hh	3,5	4,0	4,4	4,8	5,7	7,0	8,7
p	2,25	2,5	2,8	3,1	4,9	6,5	6,2
ds	2,3	2,8	3,0	3,6	4,4	5,8	7,1
dm	2,7	3,1	3,5	3,9	4,7	6,8	8,0
dm2	2,7	3,1	3,4	3,9	4,4	6,0	7,3
hm2	2,50	2,5	3,0	3,0	5,0	5,7	7,4
dh2	-	-	-	-	14,0	21,5	25,0

lg min	14	16	18	20	24	32	40
lg max	30	48	48	70	70	100	100

L min	18	20	22	25	30	39	49
L max	50	80	80	120	300	500	400

All dimensions in mm.²⁾

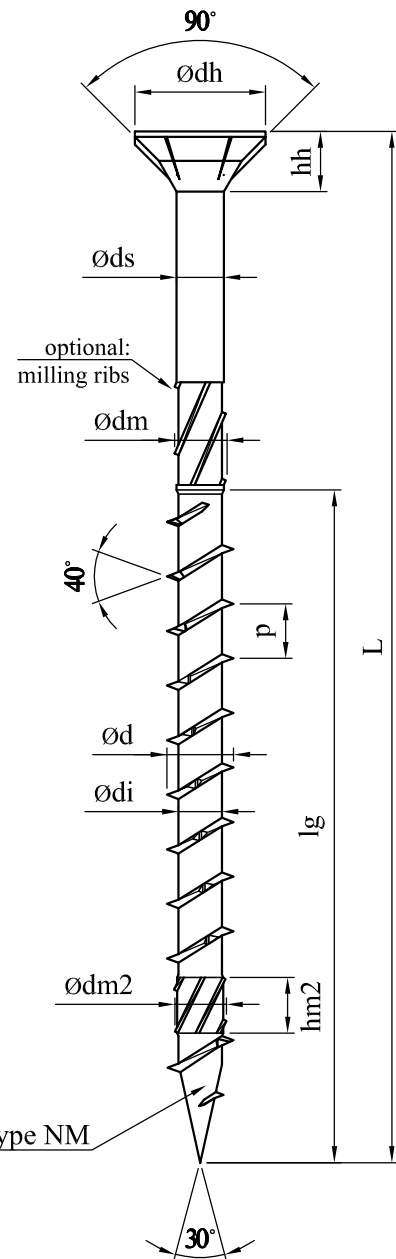

washer head

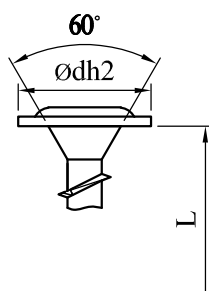

tip type 17M

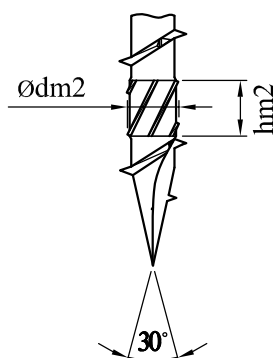

tip type NM

¹⁾ Material specification held on file by ETA Danmark.

²⁾ Tolerances according to EAD 130118-00-0603.

Speedo 4K
carbon steel¹

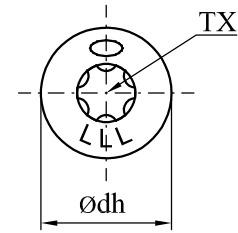

nominal size	Ø3,5	Ø4,0	Ø4,5	Ø5,0	Ø6,0	Ø8,0	Ø10,0
d	3,5	4,0	4,5	5,0	6,0	8,0	10,0
di	2,1	2,5	2,7	3,3	4,0	5,3	6,3
dh	7,0	8,0	9,0	10,0	12,0	14,5	17,8
hh	3,5	4,0	4,4	4,8	5,7	7,0	8,7
p	2,25	2,5	2,8	3,1	4,9	5,6	6,6
ds	2,3	2,8	3,0	3,6	4,3	5,7	6,9
dm	2,7	2,9	3,4	3,9	4,8	6,5	7,9
dh2	-	-	-	-	14,0	22,0	25,0
e	2,45	2,8	3,2	3,5	4,2	5,6	7,0
h4K	2,50	2,5	3,0	3,0	3,0	3,5	4,0

lg min	14	16	18	20	24	32	40
lg max	30	48	48	70	70	100	100

L min	18	20	22	25	30	39	49
L max	50	80	80	120	300	500	400

All dimensions in mm.²⁾

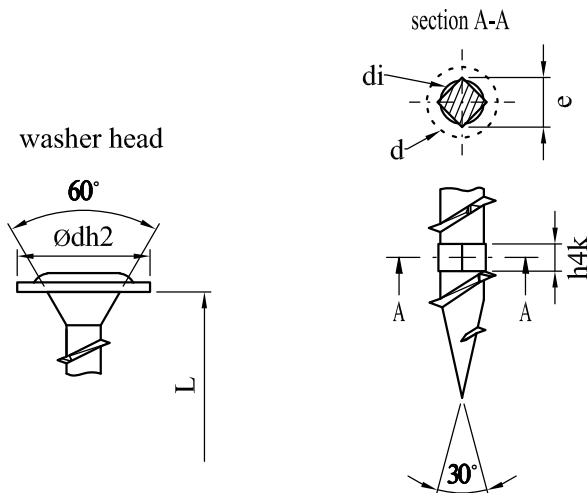
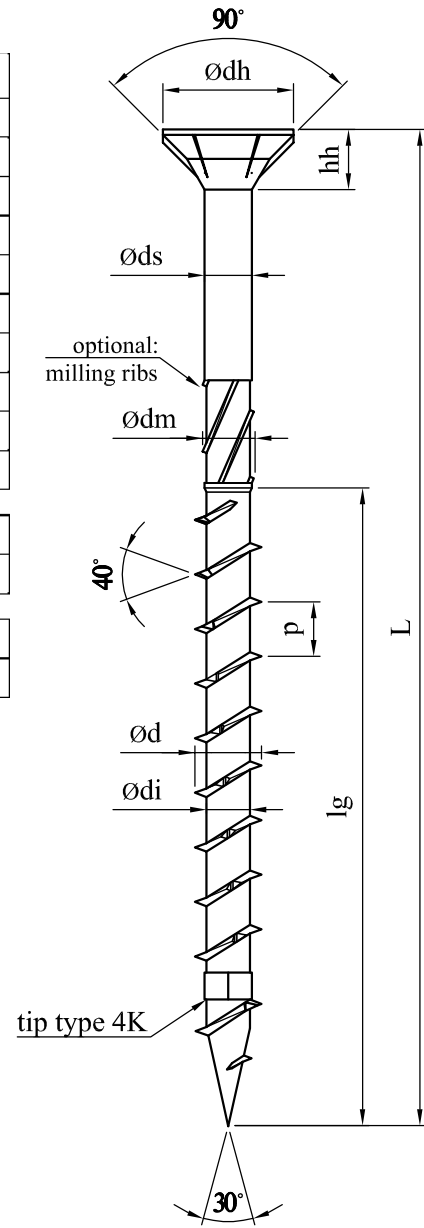

¹⁾ Material specification held on file by ETA Danmark.

²⁾ Tolerances according to EAD 130118-00-0603.

Hobotec, Hapatec, Paneltwistec V4A countersunkhead 90°

carbon steel¹
 stainless steel hardened¹
 stainless steel unhardened¹

nominal size	Ø3,5	Ø4,0	Ø4,5	Ø5,0	Ø6,0
d	3,5	4,0	4,5	5,0	6,0
di	2,1	2,5	2,7	3,3	4,0
dh	5,0	8,0	9,0	10,0	12,0
hh	3,8	4,3	4,8	5,4	5,7
p	1,60	1,8	2,0	2,2	2,6
ds	2,3	2,8	3,0	3,6	4,0
dh2	-	4,2	4,7	5,3	5,6
hh2	-	5,5	7,0	8,5	11,5
dm	2,9	3,4	3,9	4,0	4,6
dm2	2,45	2,8	3,2	3,8	4,6
dt	2,0	2,3	2,5	3,0	3,4
lt	3,40	3,9	4,4	3,8	4,9

lg min	14	16	18	20	24
lg max	30	48	48	70	70

L min	21	25	29	32	40
L max	50	80	80	120	300

All dimensions in mm.²⁾

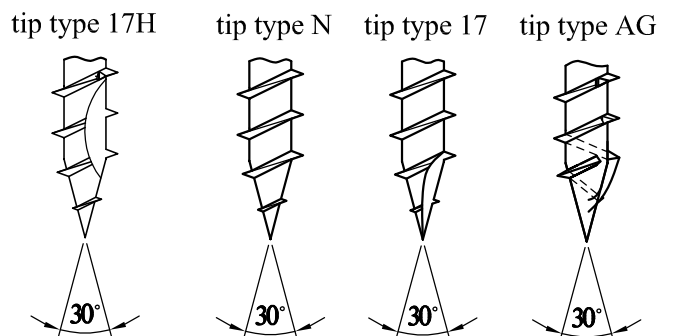
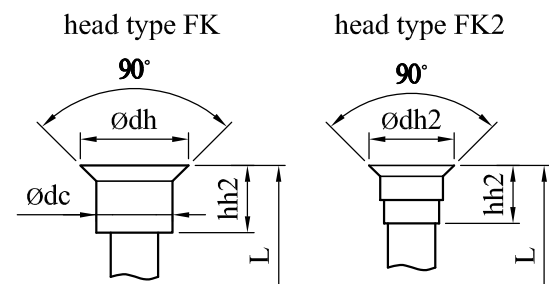
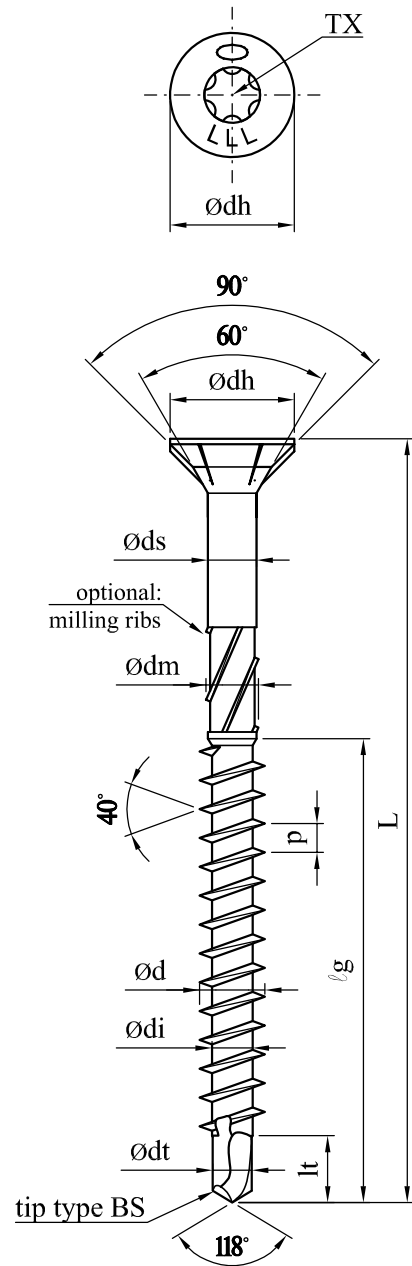

¹⁾ Material specification held on file by ETA Danmark.

²⁾ Tolerances according to EAD 130118-00-0603.

Hobotec, Hapatec, Paneltwistec V4A countersunkhead 60°

carbon steel¹
 stainless steel hardened¹
 stainless steel unhardened¹

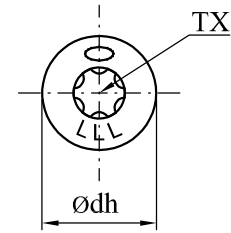

nominal size	Ø3,5	Ø4,0	Ø4,5	Ø5,0	Ø6,0
d	3,5	4,0	4,5	5,0	6,0
di	2,1	2,5	2,7	3,3	4,0
dh	5,0	6,0	7,0	7,5	8,5
hh	2,0	2,5	2,5	2,8	3,5
p	1,60	1,8	2,0	2,2	2,6
ds	2,3	2,8	3,0	3,6	4,0
dh2	-	4,2	4,7	5,3	5,6
hh2	-	5,5	7,0	8,5	11,5
dm	2,9	3,4	3,9	4,0	4,6
dm2	2,45	2,8	3,2	3,8	4,6
dt	2,0	2,3	2,5	3,0	3,4
lt	3,40	3,9	4,4	3,8	4,9

lg min	18	20	23	24	29
lg max	30	48	48	70	70

L min	19	25	29	32	40
L max	50	80	80	120	300

All dimensions in mm.²⁾

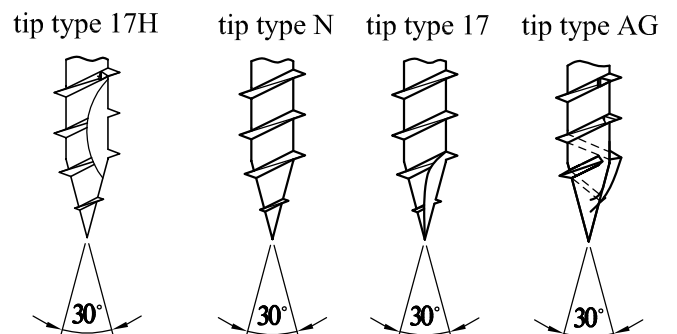
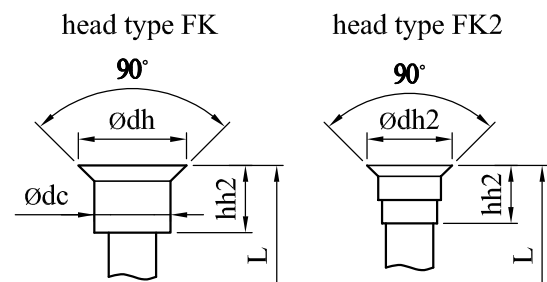
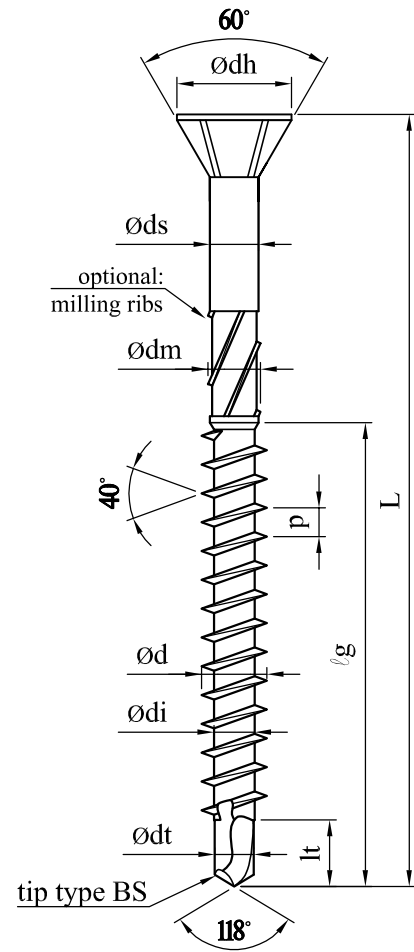

¹⁾ Material specification held on file by ETA Danmark.

²⁾ Tolerances according to EAD 130118-00-0603.

SP ZK
carbon steel¹

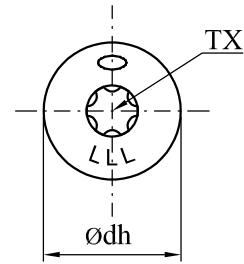

nominal size	Ø6,0	Ø8,0	Ø10,0
d	6,0	8,0	10,0
di	4,0	5,3	6,3
dh	13,4	17,0	21,0
hh	3,6	4,0	4,8
p	4,9	5,6	6,6
ds	4,3	5,7	6,9
dm	4,8	6,5	7,9

lg min	24	32	40
lg max	70	100	100

L min	28	36	45
L max	300	600	600

All dimensions in mm.²⁾

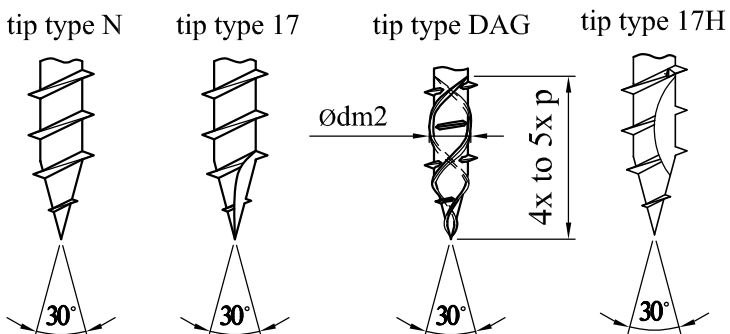
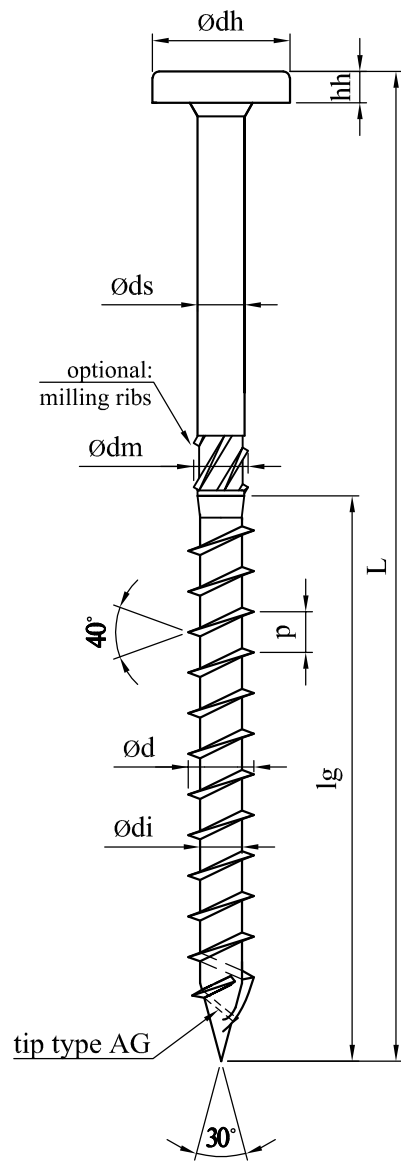

¹⁾ Material specification held on file by ETA Danmark.

²⁾ Tolerances according to EAD 130118-00-0603.

Ecotec countersunk head 90°
 carbon steel¹
 stainless steel unhardened¹

nominal size	Ø3,5	Ø4,0	Ø4,5	Ø5,0	Ø6,0
d	3,5	4,0	4,5	5,0	6,0
di	2,1	2,5	2,7	3,2	3,7
dh	7,0	8,0	9,0	10,0	12,0
hh	3,8	4,3	4,8	5,4	5,7
p	1,60	1,8	2,0	2,2	2,6
ds	2,3	2,8	3,0	3,6	4,0
dm	2,9	3,4	3,9	4,0	4,6

All dimensions in mm.²⁾

Ecotec partially threaded

lg min	14	16	18	20	24
lg max	30	48	48	70	70

L min	18	20	23	25	30
L max	50	80	80	120	300

All dimensions in mm.²⁾

Ecotec fully threaded

L min	18	20	23	25	30
L max	30	50	50	60	70

All dimensions in mm.²⁾

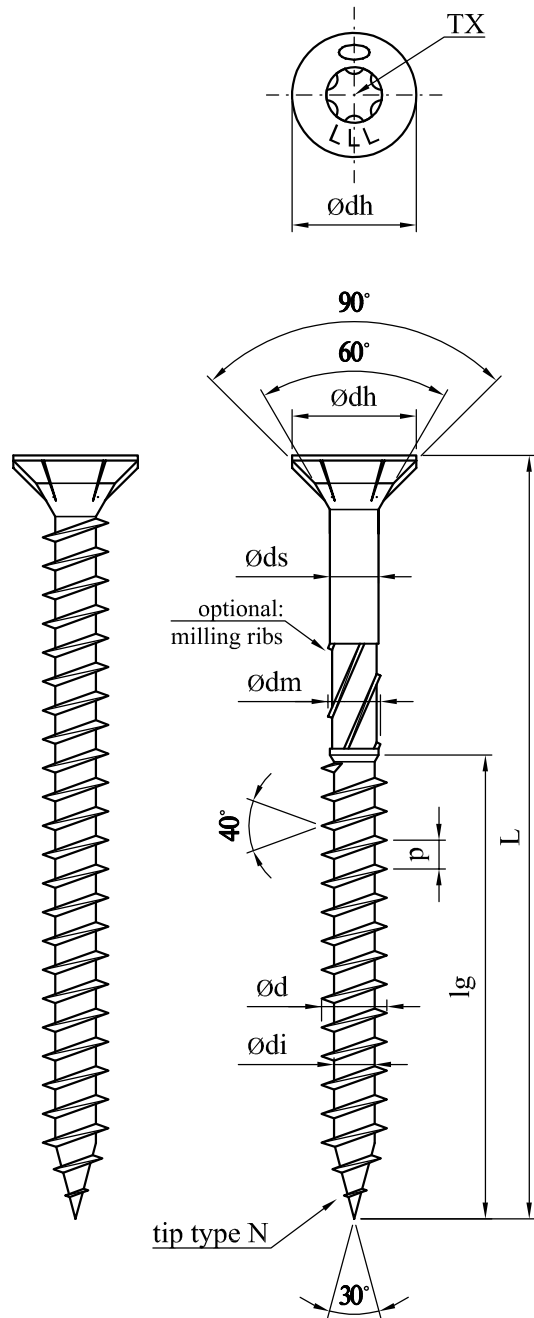

tip type 17H

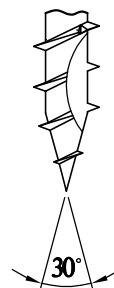

tip type 17

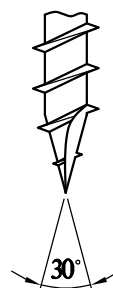

tip type AG

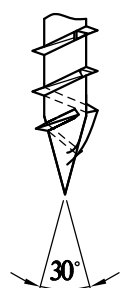

¹⁾ Material specification held on file by ETA Danmark.

²⁾ Tolerances according to EAD 130118-00-0603.

WBS - Winkelbeschlagsschraube
carbon steel¹

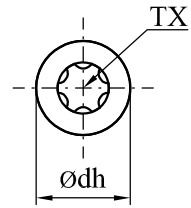

nominal size	Ø5,0
d	5,0
di	3,2
dh	7,2
hh	3,0
p	2,2
dc	4,8

lg min	20
lg max	70

L min	29
L max	80

All dimensions in mm.²⁾

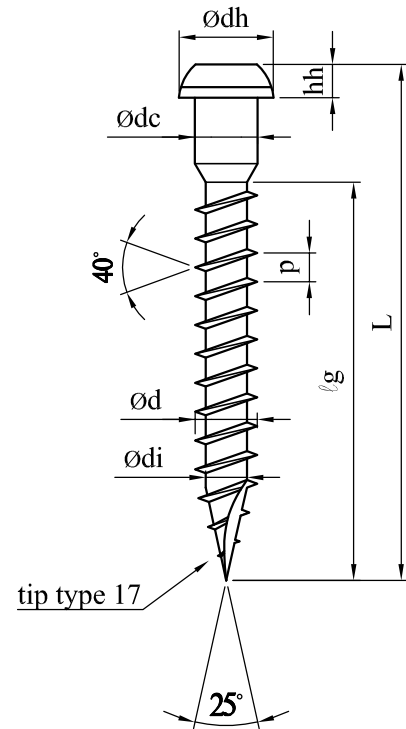

tip type 17H

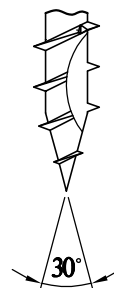

tip type N

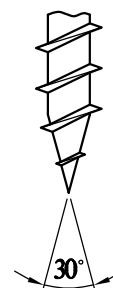

tip type AG

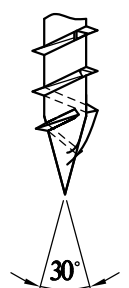

¹⁾ Material specification held on file by ETA Danmark.

²⁾ Tolerances according to EAD 130118-00-0603.

VSS - Verbinder-Systemschraube
carbon steel¹
for Ø5,0 also stainless steel unhardened and special coated¹

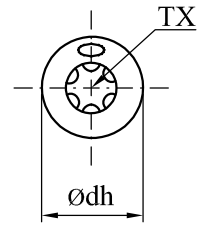

nominal size	Ø4,0	Ø5,0	Ø6,0	Ø8,0
d	4,0	5,0	6,0	8,0
di	2,3	3,2	3,9	5,5
dh	5,5	8,1	9,5	12,0
hh	4,2	5,6	6,7	8,8
p	2,5	3,1	2,2*	4,9
dc	4,0	5,0	6,0	8,0
dm2	2,80	3,80	-*	4,60

L. min	20	26	31	41
L. max	60	80	100	160

All dimensions in mm.²⁾

* p for Ø5,0 stainless steel unhardened

resp. dm2 not for stainless steel unhardened

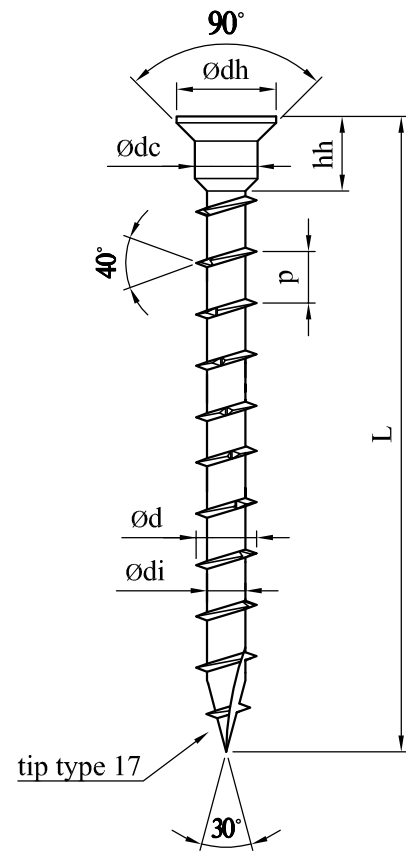

tip type 17H

tip type N

tip type AG

tip type DAG

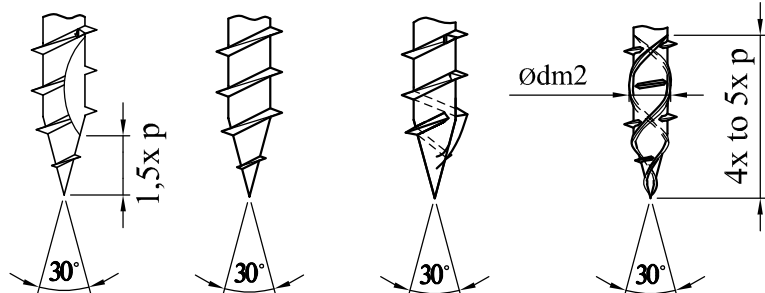

¹⁾ Material specification held on file by ETA Denmark.

²⁾ Tolerances according to EAD 130118-00-0603.

Sawtec
carbon steel¹

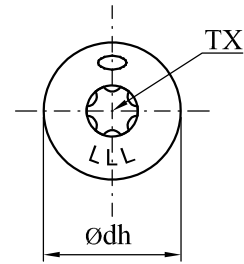

nominal size	Ø4,0	Ø4,5	Ø5,0	Ø6,0	Ø8,0	Ø10,0
d	4,0	4,5	5,0	6,0	8,0	10,0
di	2,5	2,7	3,3	4,0	5,3	6,3
dh	8,5	9,5	10,5	13,0	18,0	22,0
hh	1,7	1,7	2,3	2,4	2,6	3,1
p	2,5	2,8	3,1	4,9	5,6	6,6
ds	2,8	3,0	3,6	4,4	5,8	7,1
dm	2,9	3,4	3,9	4,9	6,7	7,9
dm2	2,8	3,2	3,8	4,6	6,2	7,2
lg min	16	18	20	24	32	40
lg max	48	48	70	70	100	100
L min	18	20	22	26	35	43
L max	80	80	120	300	600	600

All dimensions in mm.²⁾

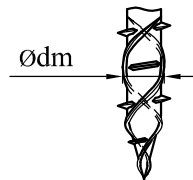
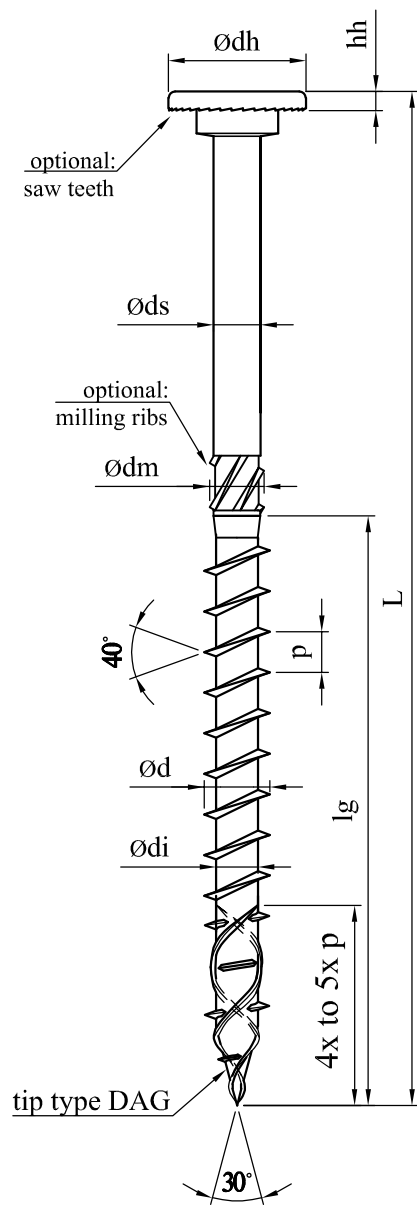

¹⁾ Material specification held on file by ETA Danmark.

²⁾ Tolerances according to EAD 130118-00-0603.

FBAS
stainless steel unhardened¹

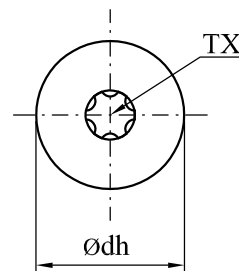

nominal size	Ø4,8	Ø5,5
d	4,8	5,5
di	3,1	3,2
dh	12,0	12,0
hh	2,7	2,7
p	2,1	2,4
ds	3,8	4,0

lg min	20	22
lg max	48	48

L min	20	22
L max	60	60

All dimensions in mm.²⁾

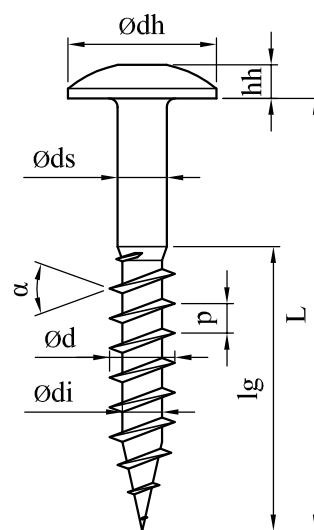

¹⁾ Material specification held on file by ETA Danmark.

²⁾ Tolerances according to EAD 130118-00-0603.

LBS TG SK
carbon steel¹

nominal size	Ø8,0
d	8,0
di	6,1
dh	15,0
hh	6,7
p	3,7
ds	6,4
dm	6,9
m	10,5
dm2	6,9

lg min	32
lg max	80

L min	39
L max	240

All dimensions in mm.²⁾

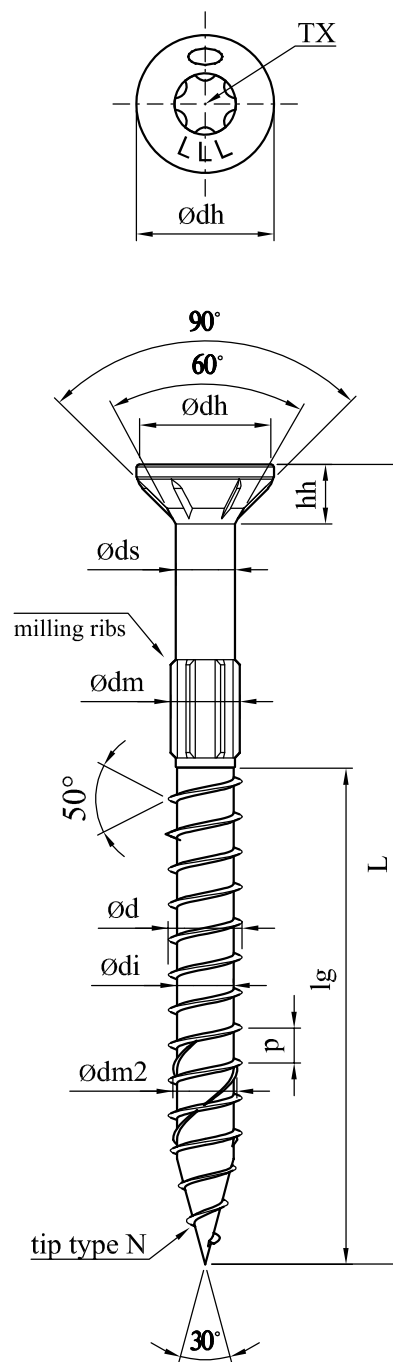

¹⁾ Material specification held on file by ETA Danmark.

²⁾ Tolerances according to EAD 130118-00-0603.

LBS VG ZK
carbon steel¹

nominal size	Ø8,0
d	8,0
di	6,1
dh	10,0
hh	6,5
p	3,8
dm	6,9

L min	39
L max	400

All dimensions in mm.²⁾

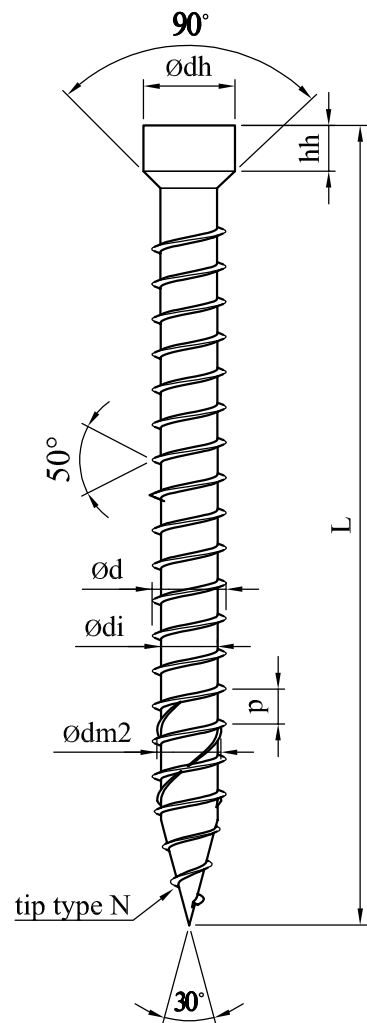
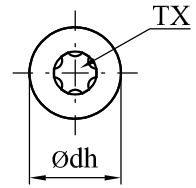

thread-free part
acceptable for:
L < 300 mm with ≈ 3 mm
L ≥ 300 mm with ≈ 3x p

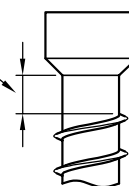

¹⁾ Material specification held on file by ETA Danmark.

²⁾ Tolerances according to EAD 130118-00-0603.

Brutus
carbon steel¹

nominal size	Ø16,0
d	16,0
d _i	11,8
p	2,1

L min	64
L max	3000

All dimensions in mm.²⁾
Threaded rod may be cut to length.

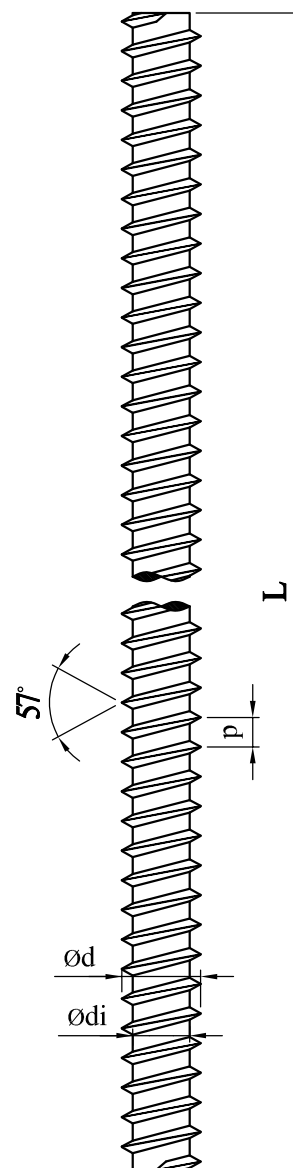

¹⁾ Material specification held on file by ETA Danmark.

²⁾ Tolerances according to EAD 130118-00-0603.

Washer
carbon steel¹

Washer for countersunk head 90°

nominal size	Ø5,0	Ø6,0	Ø8,0	Ø10,0	
d	min	5,35	7,70	8,70	11,60
	max	5,85	8,30	9,30	12,40
da	min	15,50	19,50	24,50	31,50
	max	16,50	20,50	25,50	32,50
dh	min	9,90	13,60	16,00	22,00
	max	10,70	14,40	17,00	23,00
h	min	2,50	4,30	5,30	6,30
	max	2,90	4,70	5,70	6,70

All dimensions in mm.

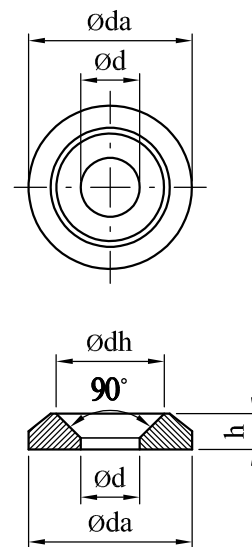

Washer for head type FK 125°

nominal size	Ø8,0	
d	min	10,30
	max	10,90
da	min	27,00
	max	28,00
dh	min	18,20
	max	19,00
h	min	7,00
	max	7,80

All dimensions in mm.

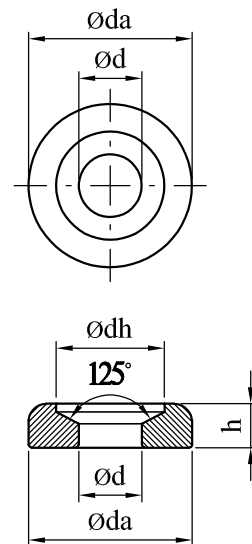

¹Material specification held on file by ETA Danmark.

Annex B Minimum distances and spacing

Axially loaded screws
Single configuration

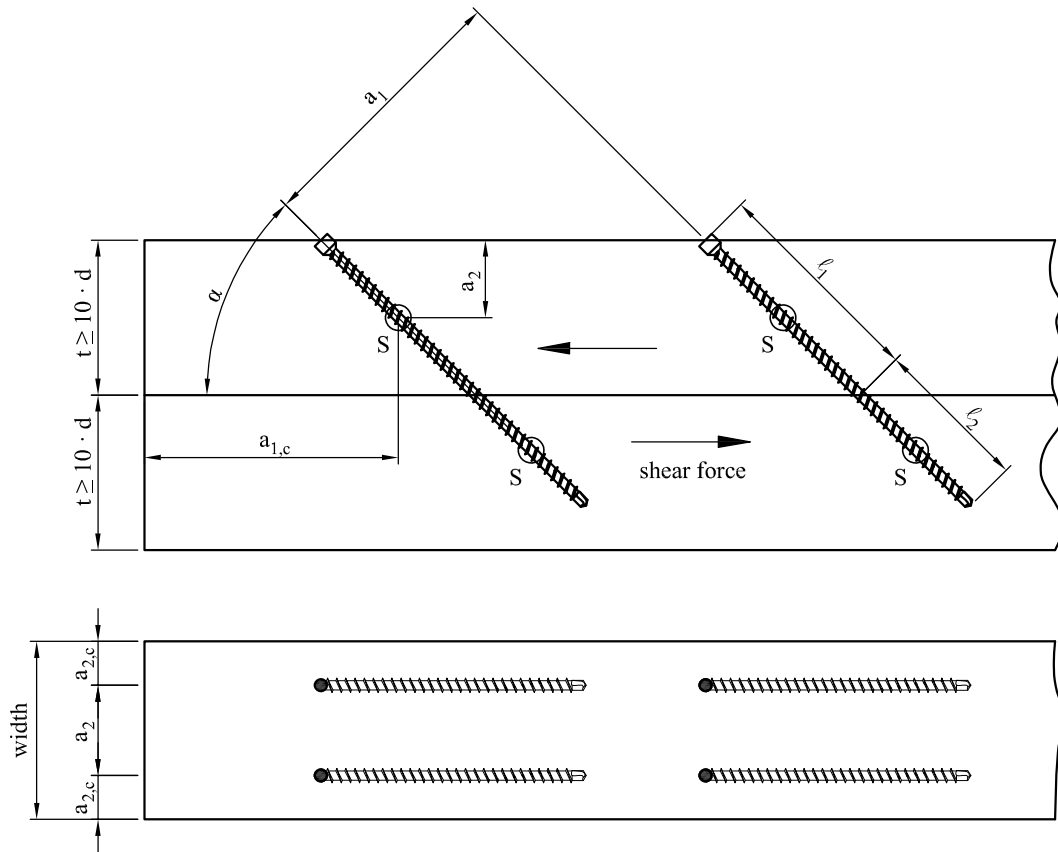

S = centroid of the part of the screw in the timber

Minimum distances and spacings for exclusively axially loaded screws in non-predrilled holes.
Minimum timber thickness $t = 10 \cdot d$, minimum timber width $w = \max \{8 \cdot d; 60 \text{ mm}\}$.
 $a_1 \geq 5 \cdot d$ $a_2 \geq 5 \cdot d$ $a_{1,c} \geq 10 \cdot d$ $a_{2,c} \geq 4 \cdot d$

Minimum distances and spacings for exclusively axially loaded screws in predrilled holes or for screws with tip type BS or rBS DAG in non-predrilled holes. Minimum timber thickness $t = 10 \cdot d$, minimum timber width $w = \max \{8 \cdot d; 60 \text{ mm}\}$.
 $a_1 \geq 5 \cdot d$ $a_2 \geq 5 \cdot d$ $a_{1,c} \geq 5 \cdot d$ $a_{2,c} \geq 3 \cdot d$

Spacing a_2 may be reduced from $5 \cdot d$ to $2,5 \cdot d$, if the condition $a_1 \cdot a_2 \geq 25 \cdot d^2$ is fulfilled.

For a crossed screw couple the minimum spacing between the crossing screws is $1,5 \cdot d$.

Minimum distances and spacings, see also 3.12
 $0^\circ \leq \alpha \leq 90^\circ$ for all tip types except tip type BS, see also 3.9
 $30^\circ \leq \alpha \leq 90^\circ$ for screws with tip type BS, see also 3.9

Axially loaded screws
Crosswise configuration

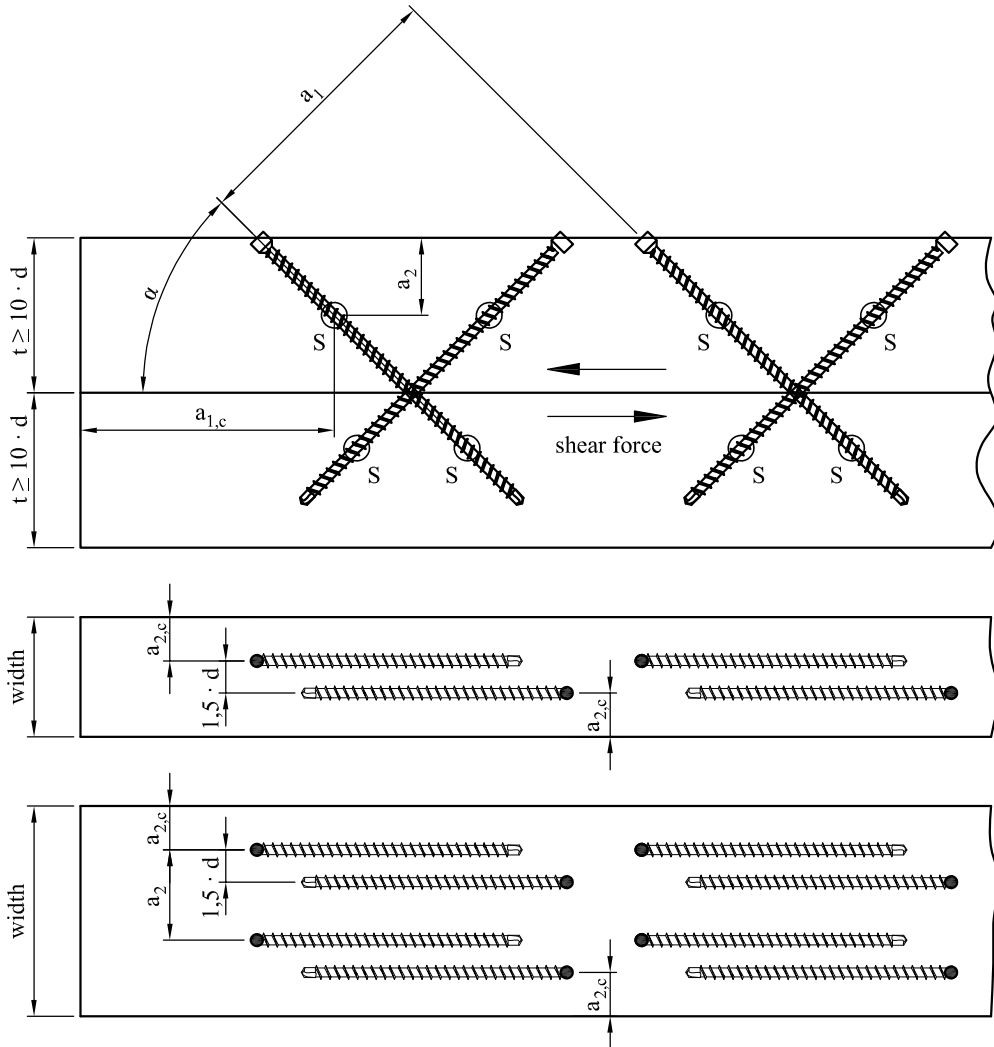

S = centroid of the part of the screw in the timber

Minimum distances and spacings for exclusively axially loaded screws in non-predrilled holes.

Minimum timber thickness $t = 10 \cdot d$, minimum timber width $w = \max \{8 \cdot d; 60 \text{ mm}\}$.

$$a_1 \geq 5 \cdot d \quad a_2 \geq 5 \cdot d \quad a_{1,c} \geq 10 \cdot d \quad a_{2,c} \geq 4 \cdot d$$

Minimum distances and spacings for exclusively axially loaded screws in predrilled holes or for screws with tip type BS or rBS DAG in non-predrilled holes. Minimum timber thickness $t = 10 \cdot d$, minimum timber width $w = \max \{8 \cdot d; 60 \text{ mm}\}$.

$$a_1 \geq 5 \cdot d \quad a_2 \geq 5 \cdot d \quad a_{1,c} \geq 5 \cdot d \quad a_{2,c} \geq 3 \cdot d$$

Spacing a_2 may be reduced from $5 \cdot d$ to $2,5 \cdot d$, if the condition $a_1 \cdot a_2 \geq 25 \cdot d^2$ is fulfilled.

For a crossed screw couple the minimum spacing between the crossing screws is $1,5 \cdot d$.

Minimum distances and spacings, see also 3.12

$0^\circ \leq \alpha \leq 90^\circ$ for all tip types except tip type BS, see also 3.9

$30^\circ \leq \alpha \leq 90^\circ$ for screws with tip type BS, see also 3.9

Axially or laterally loaded screws in the plane or edge surface of cross laminated timber

Figure 1: Definition of spacing, end and edge distances in the plane surface (wide face) unless otherwise specified in the technical specification (ETA or hEN) for the cross laminated timber:

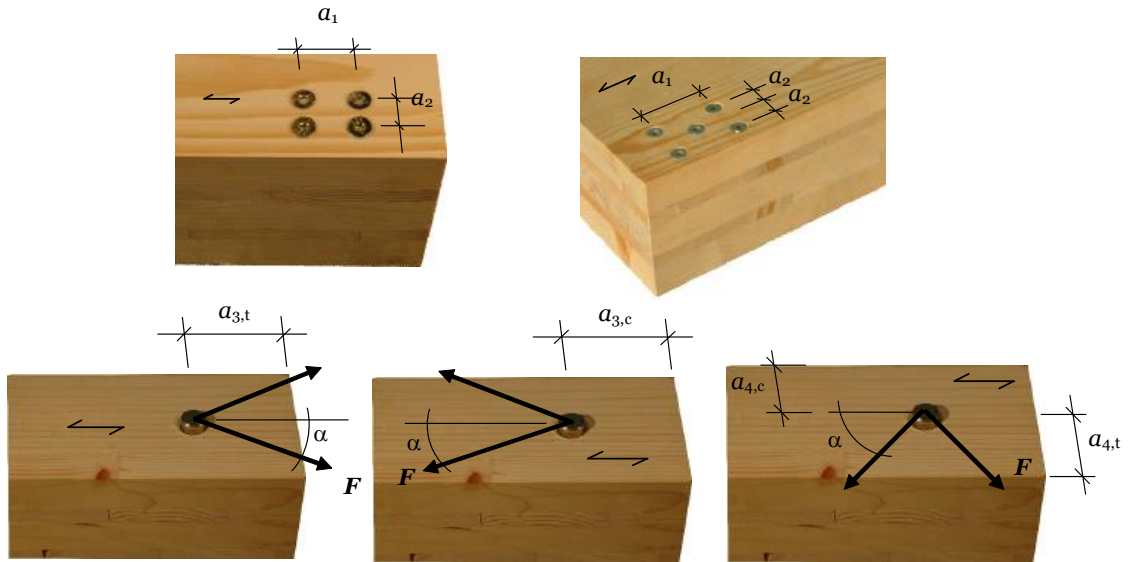
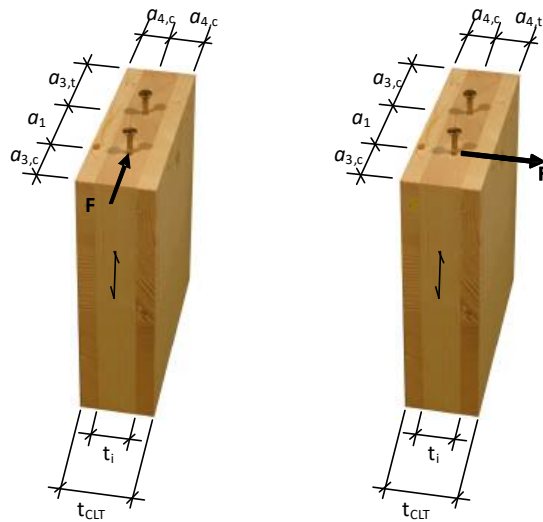

Figure 2: Definition of spacing, end and edge distances in the edge surface unless otherwise specified in the technical specification (ETA or hEN) for the cross laminated timber:



Minimum distances and spacing for screws in the plane surface (wide surface) or edge surface of cross laminated timber

	a_1	$a_{3,t}$	$a_{3,c}$	a_2	$a_{4,t}$	$a_{4,c}$
Plane surface (wide face). see figure 1	$4 \cdot d$	$6 \cdot d$	$6 \cdot d$	$2.5 \cdot d$	$6 \cdot d$	$2.5 \cdot d$
Edge surface. see figure 2	$10 \cdot d$	$12 \cdot d$	$7 \cdot d$	$4 \cdot d$	$6 \cdot d$	$3 \cdot d$

Annex C Compression reinforcement

„KonstruX“ screws or "Brutus" threaded rods with a full thread may be used for reinforcement of timber members with compression stresses at an angle α to the grain of $45^\circ \leq \alpha \leq 90^\circ$. The compression force must be evenly distributed over all screws.

The characteristic load-carrying capacity for a contact area with screws with a full thread at an angle α to the grain of $45^\circ < \alpha < 90^\circ$ shall be calculated from:

$$F_{90,Rd} = \min \left\{ \begin{array}{l} k_{c,90} \cdot B \cdot \ell_{ef,1} \cdot f_{c,90,d} + n \cdot \min (F_{ax,Rd}; F_{ki,Rd}) \\ B \cdot \ell_{ef,2} \cdot f_{c,90,d} \end{array} \right\}$$

Where

$F_{90,Rd}$	design load-carrying capacity of reinforced contact area [N]
$k_{c,90}$	factor for compression perpendicular to the grain according to EN 1995-1-1
B	bearing width [mm]
$\ell_{ef,1}$	effective length of contact area according to EN 1995-1-1 [mm]
$f_{c,90,d}$	design compressive strength perpendicular to the grain [N/mm ²]
n	number of reinforcement screws, $n = n_0 \cdot n_{90}$
n_0	number of reinforcement screws arranged in a row parallel to the grain
n_{90}	number of reinforcement screws arranged in a row perpendicular to the grain
$F_{ax,Rd}$	design axial withdrawal capacity [N]
$F_{ki,Rd}$	design buckling capacity [N]
$\ell_{ef,2}$	effective distribution length in the plane of the screw tips [mm]
$\ell_{ef,2}$	$= \ell_{ef} + (n - 1) \cdot a + \min(\ell_{ef}; a_{1,c})$ for end bearings [mm]
$\ell_{ef,2}$	$= 2 \cdot \ell_{ef} + (n_0 - 1) \cdot a_1$ for centre-bearings [mm]
a_1	spacing parallel to the grain [mm]
$a_{1,c}$	end distance [mm]

Reinforcing screws or threaded rods for wood-based panels are not covered by this European Technical Assessment.

Reinforced end bearing

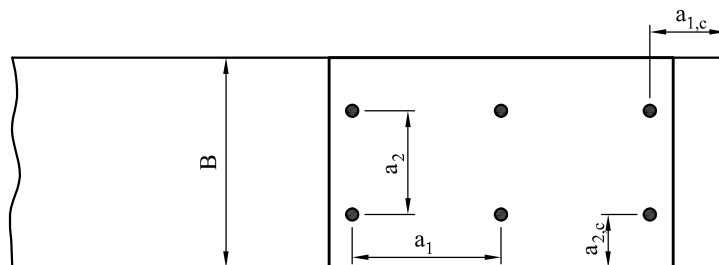
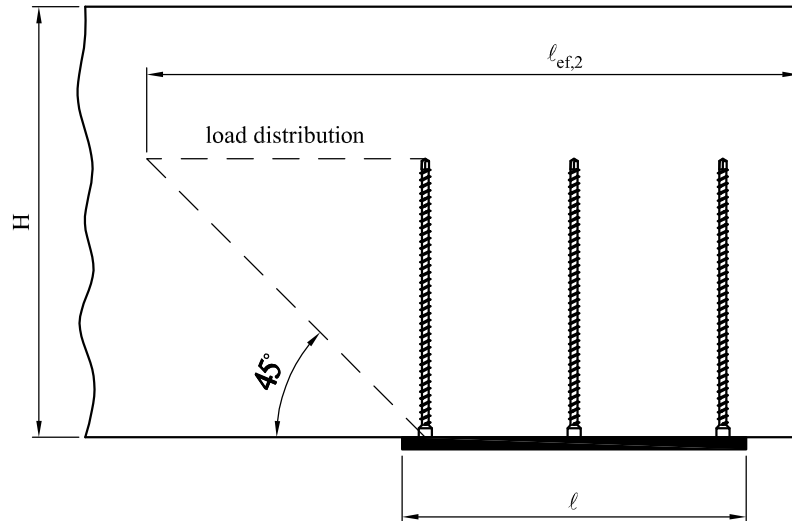

- H component height [mm]
 B bearing width [mm]
 l_{ef} point side penetration length [mm]
 $l_{ef,2}$ effective distribution length in the plane of the screw tips [mm]
 $= l_{ef} + (n_0 - 1) \cdot a_1 + \min(l_{ef}; a_{1,c})$ for end bearings

Reinforced centre-bearing

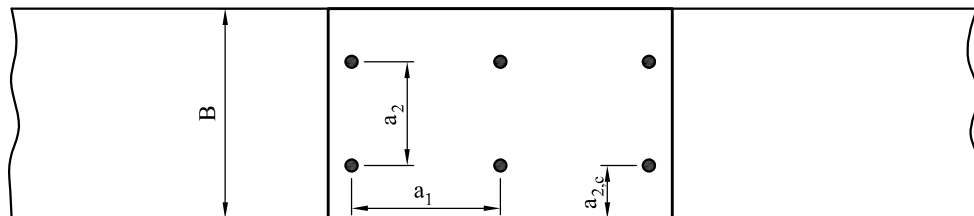
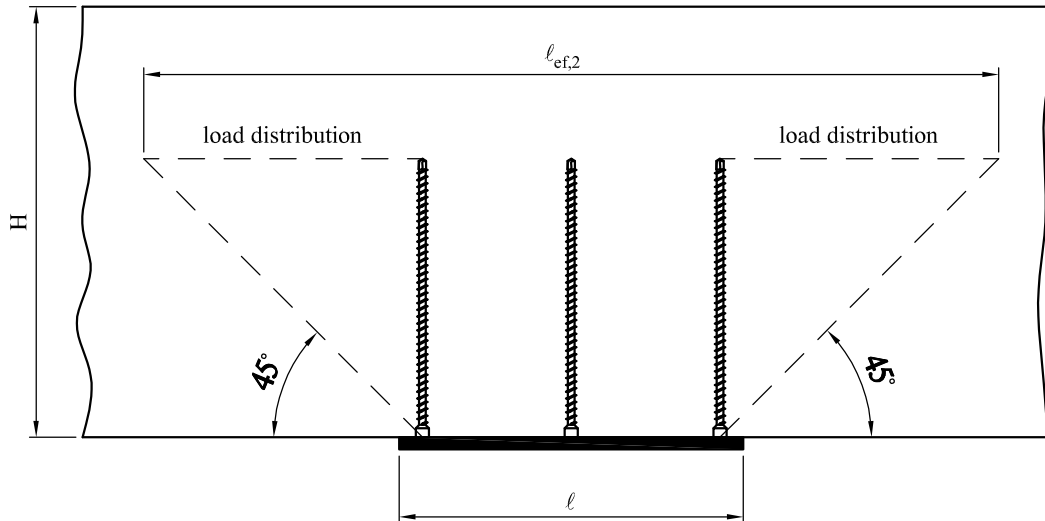

- H component height [mm]
- B bearing width [mm]
- l_{ef} point side penetration length [mm]
- $l_{ef,2}$ effective distribution length in the plane of the screw tips [mm]
 $= 2 \cdot l_{ef} + (n_0 - 1) \cdot a_1$ for centre-bearings

Annex D Tensile reinforcement perpendicular to grain

Timber member loaded by a connection force perpendicular to the grain

„KonstruX“ screws or "Brutus" threaded rods with a full thread may be used for reinforcement of timber members with tensile stresses perpendicular to the grain. The tensile force must be evenly distributed over all screws.

Unless specified otherwise in national provisions that apply at the installation site, the axial capacity of a reinforcement of a timber member loaded by a connection force perpendicular to the grain shall fulfil the following condition:

$$\frac{[1 - 3 \cdot \alpha^2 + 2 \cdot \alpha^3] \cdot F_{90,d}}{F_{ax,Rd}} \leq 1$$

Where

$F_{90,d}$ design value of the force component perpendicular to the grain [N]

$\alpha = a/h$ [mm]

h member depth [mm]

$F_{ax,Rd}$ minimum of the design values of the withdrawal capacity and the tensile capacity of the reinforcing screws or threaded rods where ℓ_{ef} is the smaller value of the penetration depth below or above the potential crack [N]

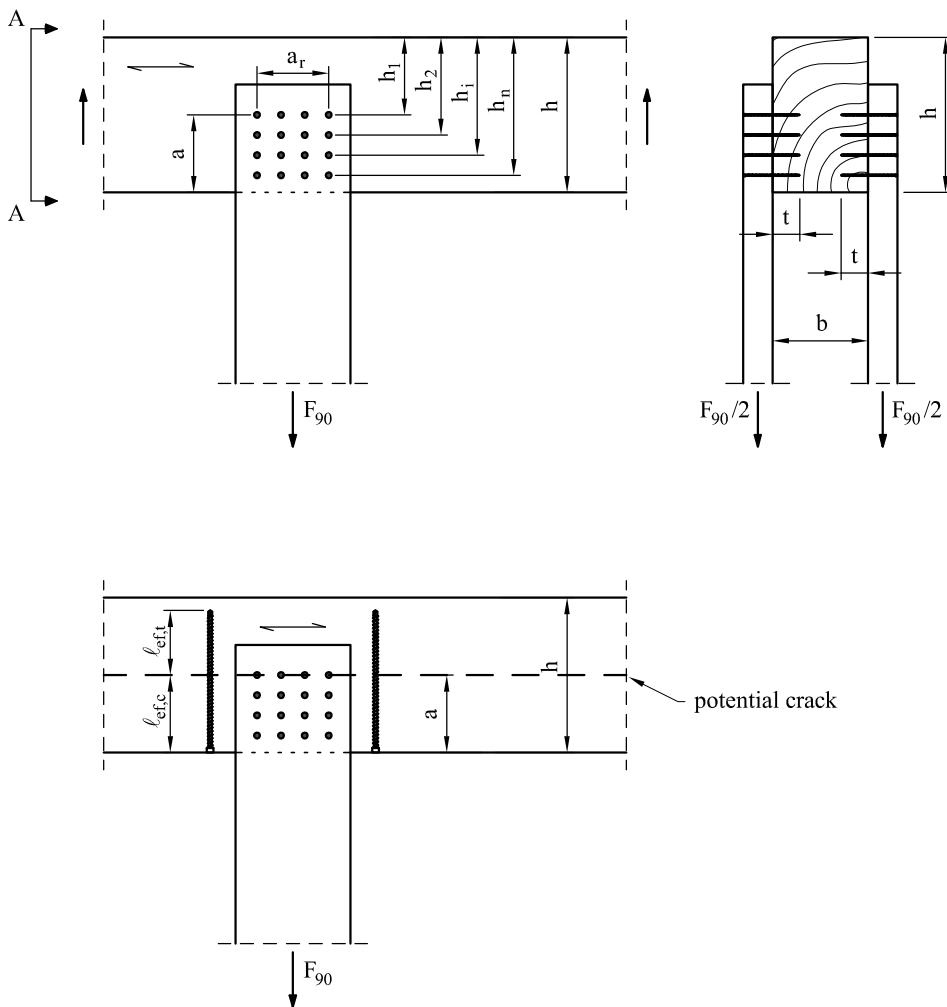

Notched beam support

Unless specified otherwise in national provisions that apply at the installation site, the axial capacity of a reinforcement of a notched beam support shall fulfil the following condition:

$$\frac{1,3 \cdot V_d \cdot [3 \cdot (1 - \alpha)^2 - 2 \cdot (1 - \alpha)^3]}{F_{ax,Rd}} \leq 1$$

Where

V_d design value of the shear force [N]

$\alpha = h_{ef}/h$ [mm]

h member depth [mm]

$F_{ax,Rd}$ minimum of the design values of the withdrawal capacity and the tensile capacity of the reinforcing screws or threaded rods where ℓ_{ef} is the smaller value of the penetration depth below or above the potential crack [N]

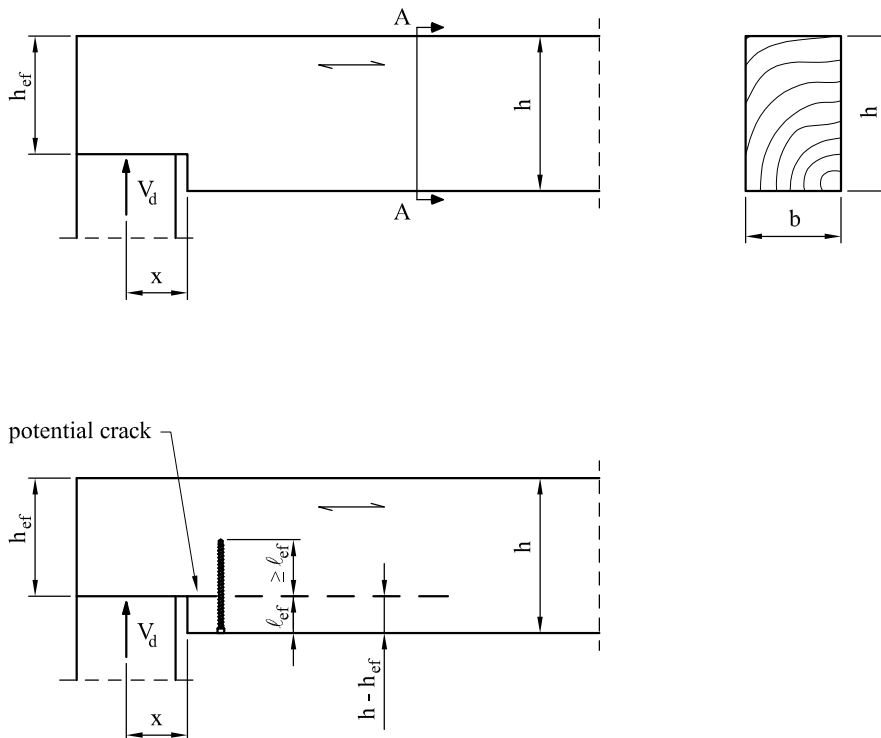

Beam hole

Unless specified otherwise in national provisions that apply at the installation site, the axial capacity of a reinforcement of a hole in a beam shall fulfil the following condition:

$$\frac{F_{t,V,d} + F_{t,M,d}}{F_{ax,Rd}} \leq 1$$

Where

$F_{t,V,d}$ design value of the force perpendicular to the grain due to shear force:

$$F_{t,V,d} = \frac{V_d \cdot h_d}{4 \cdot h} \cdot \left[3 - \frac{h_d^2}{h^2} \right] \quad [\text{N}]$$

V_d design value of the shear force [N]

h member depth [mm]

h_d hole depth for rectangular holes [mm]

h_d 70 % of hole diameter for circular holes [mm]

$F_{t,M,d}$ design value of the force perpendicular to the grain due to bending moment:

$$F_{t,M,d} = 0,008 \cdot \frac{M_d}{h_r} \quad [\text{N}]$$

M_d design value of the member bending moment at the hole end [Nmm]

$h_r = \min(h_{ro}; h_{ru})$ for rectangular holes [mm]

$h_r = \min(h_{ro}; h_{ru}) + 0,15 \cdot h_d$ for circular holes [mm]

$F_{ax,Rd}$ minimum of the design values of the withdrawal capacity and the tensile capacity of the reinforcing screws or threaded rods where ℓ_{ef} is the smaller value of the penetration depth below or above the potential crack [N]

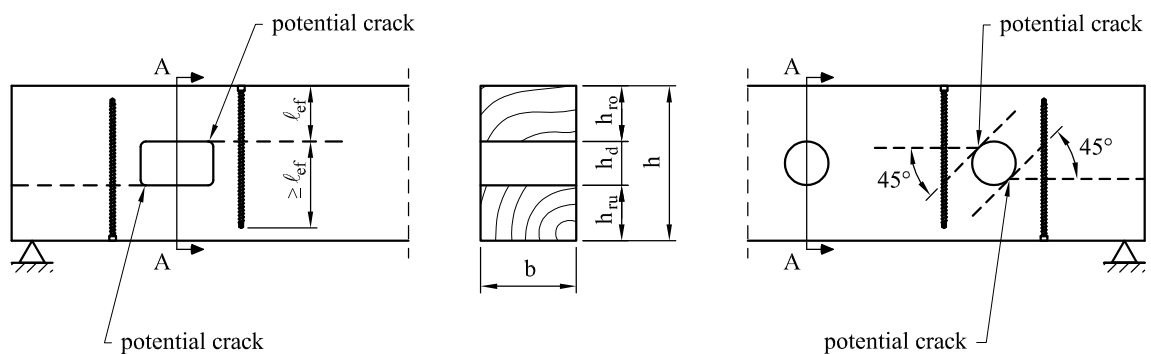

Annex E
Thermal insulation on top of rafters

E.u.r.o.Tec screws with an outer thread diameter $6 \text{ mm} \leq d \leq 12 \text{ mm}$ may be used for the fixing of heat insulation on top of rafters.

The thickness of the insulation shall not exceed 400 mm. The rafter insulation must be placed on top of solid timber or glued laminated timber rafters or cross-laminated timber members and be fixed by battens arranged parallel to the rafters or by wood-based panels on top of the insulation layer. The insulation of vertical facades is also covered by the rules given here.

Screws must be screwed in the rafter through the battens or panels and the insulation without pre-drilling in one sequence.

The angle α between the screw axis and the grain direction of the rafter should be between 30° and 90° .

The rafter consists of solid timber (softwood) according to EN 338, glued laminated timber according to EN 14081, cross-laminated timber, or laminated veneer lumber according to EN 14374 or to European Technical Assessment or similar glued members according to European Technical Assessment.

The battens must be from solid timber (softwood) according to EN 338. The minimum thickness t and the minimum width b of the solid timber battens is given as follows:

Screws $d \leq 8,0 \text{ mm}$:	$b_{\min} = 50 \text{ mm}$	$t_{\min} = 30 \text{ mm}$
Screws $d = 10,0 \text{ mm}$:	$b_{\min} = 60 \text{ mm}$	$t_{\min} = 40 \text{ mm}$
Screws $d = 12,0 \text{ mm}$:	$b_{\min} = 80 \text{ mm}$	$t_{\min} = 100 \text{ mm}$

The insulation must comply with a European Technical Assessment.

Friction forces shall not be considered for the design of the characteristic axial capacity of the screws.

The anchorage of wind suction forces as well as the bending stresses of the battens or the boards, respectively, shall be considered in design. Additional screws perpendicular to the grain of the rafter (angle $\alpha = 90^\circ$) may be arranged if necessary.

The maximum screw spacing is $e_s = 1,75 \text{ m}$.

Thermal insulation on rafters with parallel inclined screws

Mechanical model

The system of rafter, heat insulation material on top of rafter and battens parallel to the rafter may be considered as a beam on elastic foundation. The batten represents the beam, and the heat insulation material on top of the rafter the elastic foundation. The minimum compression stress of the heat insulation material at 10 % deformation, measured according to EN 826¹, shall be $\sigma_{10\%} = 0,05 \text{ N/mm}^2$. The batten is loaded perpendicular to the axis by point loads F_b . Further point loads F_s are from the shear load of the roof due to dead and snow load, which are transferred from the screw heads into the battens.

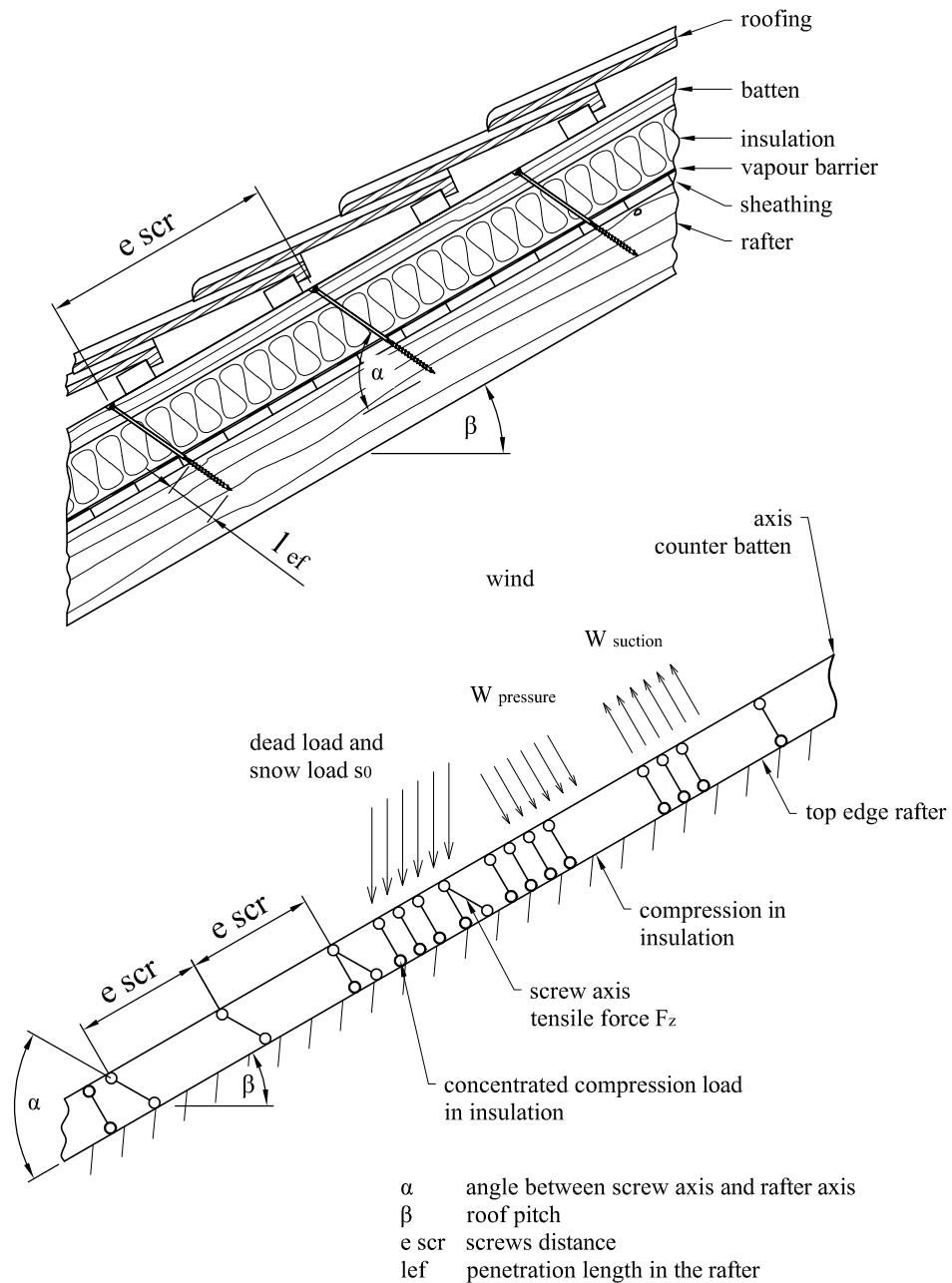

¹EN 826:1996 Thermal insulating products for building applications - Determination of compression behaviour

Thermal insulation on rafters with parallel inclined screws

Design of the battens

The bending stresses are calculated as:

$$M = \frac{(F_b + F_s) \cdot \ell_{\text{char}}}{4}$$

Where

F_b point loads perpendicular to the battens [N]

F_s point loads perpendicular to the battens, load application in the area of the screw heads [N]

ℓ_{char} characteristic length $\ell_{\text{char}} = \sqrt[4]{\frac{4 \cdot EI}{w_{\text{ef}} \cdot K}}$ [mm]

EI bending stiffness of the batten [$\text{N}/\text{mm}^2 \cdot \text{mm}^4$]

w_{ef} effective width of the thermal insulation material [mm]

K coefficient of subgrade

The coefficient of subgrade K may be calculated from the modulus of elasticity E_{HI} and the thickness t_{HI} of the heat insulation material if the effective width w_{ef} of the heat insulation material under compression is known. Due to the load extension in the heat insulation material the effective width w_{ef} is greater than the width of the batten or rafter, respectively. For further calculations, the effective width w_{ef} of the heat insulation material may be determined according to:

$$w_{\text{ef}} = w + t_{\text{HI}}/2$$

Where

w minimum width of the batten or rafter, respectively [mm]

t_{HI} thickness of the heat insulation [mm]

$$K = \frac{E_{\text{HI}}}{t_{\text{HI}}}$$

The following condition shall be satisfied:

$$\frac{\sigma_{\text{m,d}}}{f_{\text{m,d}}} = \frac{M_{\text{d}}}{W \cdot f_{\text{m,d}}} \leq 1$$

For the calculation of the section modulus W of the net cross section has to be considered.

The shear stresses shall be calculated according to:

$$V = \frac{(F_b + F_s)}{2}$$

The following condition shall be satisfied:

$$\frac{\tau_{\text{d}}}{f_{\text{v,d}}} = \frac{1,5 \cdot V_{\text{d}}}{A \cdot f_{\text{v,d}}} \leq 1$$

Design of the heat insulation material

The compressive stresses in the thermal insulation material shall be calculated according to:

$$\sigma = \frac{1,5 \cdot F_b + F_s}{2 \cdot \ell_{\text{char}} \cdot w}$$

The design value of the compressive stress shall not be greater than 110 % of the compressive stress at 10 % deformation calculated according to EN 826.

Thermal insulation on rafters with parallel inclined screws

Design of the screws

Alternatively to the battens, wood-based panels with a minimum thickness of 20 mm from plywood according to EN 636, particle board according to EN 312, oriented strand board OSB/3 and OSB/4 according to EN 300 or European Technical Approval and solid wood panels according to EN 13353 or cross laminated timber may be used.

The insulation must have a minimum compressive stress of $\sigma_{10\%} = 0,05 \text{ N/mm}^2$ at 10 % deformation according to EN 826.

The analysis of the fixing of the insulation and battens or boards, respectively, may be carried out using the static model showed on previous pages. The battens or boards, respectively, must have sufficient strength and stiffness. The maximum design value of the compressive stress between the battens or boards, respectively, and the insulation shall not exceed $1,1 \cdot \sigma_{10\%}$.

The screws are loaded predominantly axially. The axial tension force in the screw may be calculated from the shear loads of the roof R_s :

$$T_s = \frac{R_s}{\cos \alpha}$$

The design axial capacity of the "Paneltwistec", "Sawtec", "SP FK", "Speedo" and "SP ZK" screws for rafter or facade insulation shall be calculated from:

$$F_{ax,\alpha,Rd} = \min \left\{ k_{ax} \cdot f_{ax,d} \cdot d \cdot \ell_{ef,r} \cdot k_1 \cdot k_2 \cdot \left(\frac{\rho_{k,r}}{350} \right)^{0,8} ; f_{head,d} \cdot d_h^2 \cdot \left(\frac{\rho_{k,b}}{350} \right)^{0,8} ; \frac{f_{tens,k}}{\gamma_{M2}} \right\}$$

The design axial capacity of the "KonstruX" or "Topduo" screws for rafter or facade insulation shall be calculated from:

$$F_{ax,\alpha,Rd} = \min \left\{ k_{ax} \cdot f_{ax,d} \cdot d \cdot \ell_{ef,r} \cdot k_1 \cdot k_2 \cdot \left(\frac{\rho_{k,r}}{350} \right)^{0,8} ; \max \left\{ f_{head,d} \cdot d_h^2 ; k_{ax} \cdot f_{ax,d} \cdot d \cdot \ell_{ef,b} \right\} \cdot \left(\frac{\rho_{k,b}}{350} \right)^{0,8} ; \frac{f_{tens,k}}{\gamma_{M2}} \right\}$$

Where

$F_{ax,\alpha,Rd}$ design axial capacity of the screw at an angle α to the grain [N]

$k_{ax} = 1,0$ for $45^\circ \leq \alpha \leq 90^\circ$

$= 0,3 + (0,7 \cdot \alpha/45^\circ)$ for $0^\circ \leq \alpha < 45^\circ$

$f_{ax,d}$ design withdrawal parameter [N/mm²]

d outer thread diameter [mm]

d_h head diameter [mm]

$\ell_{ef,r}$ point side penetration length of the threaded part according to EN 1995-1-1 [mm]

$\ell_{ef,b}$ length of the threaded part in the batten [mm]

α angle between grain and screw axis ($\alpha \geq 30^\circ$)

$k_1 = \min \{1; 220/t_{HI}\}$

$k_2 = \min \{1; \sigma_{10\%}/0,12\}$

If equation k_1 and k_2 are considered, the deflection of the battens does not need to be considered.

t_{HI} thickness of the heat insulation [mm]

$\sigma_{10\%}$ compressive stress of the heat insulation under 10 % deformation [N/mm²]

$\sigma_{10\%} \geq 0,05 \text{ N/mm}^2$

$\rho_{k,r}$ characteristic density of the rafter [kg/m³]

$\rho_{k,b}$ characteristic density of the batten [kg/m³]

$f_{head,d}$ design head pull-through parameter [N/mm²]

$f_{tens,k}$ characteristic tensile capacity [N]

γ_{M2} partial safety factor according to EN 1993-1-1 or according to national annex

Thermal insulation on rafters with parallel inclined screws

Fixing of battens with parallel screws perpendicular to the roof plane

Alternatively to the battens, wood-based panels with a minimum thickness of 20 mm from plywood according to EN 636, particle board according to EN 312, oriented strand board OSB/3 and OSB/4 according to EN 300 or European Technical Assessment and solid wood panels according to EN 13353 or cross laminated timber may be used.

The insulation must have a minimum compressive stress of $\sigma_{10\%} = 0,05 \text{ N/mm}^2$ at 10 % deformation according to EN 826.

The battens or wood-based panels, respectively, must have sufficient strength and stiffness. The maximum design value of the compressive stress between the battens or boards, respectively, and the insulation shall not exceed $1,1 \cdot \sigma_{10\%}$.

The characteristic load-carrying capacity of the screws loaded in shear may be calculated from:

$$F_{v,Rk} = \min \left\{ \begin{array}{l} f_{h,b,k} \cdot d \cdot t_b \\ f_{h,r,k} \cdot d \cdot t_r \\ \frac{f_{h,b,k} \cdot d \cdot \beta}{1 + \beta} \cdot \left(\sqrt{4t_{il}^2 + \left(2 + \frac{1}{\beta}\right)t_b^2 + (2 + \beta)t_r^2 + 4t_{il}(t_b + t_r) + 2t_b t_r - 2t_{il} - t_b - t_r} \right) + \frac{F_{ax,Rk}}{4} \\ 1,05 \cdot \frac{f_{h,b,k} \cdot d \cdot \beta}{\frac{1}{2} + \beta} \cdot \left(\sqrt{t_{il}^2 + t_{il}t_b + \frac{t_b^2}{2}\left(1 + \frac{1}{\beta}\right) + \frac{M_{y,k}}{f_{h,b,k} \cdot d}\left(1 + \frac{2}{\beta}\right) - t_{il} - \frac{t_b}{2}} \right) + \frac{F_{ax,Rk}}{4} \\ 1,05 \cdot \frac{f_{h,b,k} \cdot d \cdot \beta}{\frac{1}{2} + \beta} \cdot \left(\sqrt{t_{il}^2 + t_{il}t_r + \frac{t_r^2}{2}\left(1 + \beta\right) + \frac{M_{y,k}}{f_{h,b,k} \cdot d}\left(2 + \frac{1}{\beta}\right) - t_{il} - \frac{t_r}{2}} \right) + \frac{F_{ax,Rk}}{4} \\ 1,15 \cdot \frac{f_{h,b,k} \cdot d \cdot \beta}{1 + \beta} \cdot \left(\sqrt{\beta^2 t_{il}^2 + 4\beta(\beta + 1) \cdot \frac{M_{y,k}}{f_{h,b,k} \cdot d} - \beta t_{il}} \right) + \frac{F_{ax,Rk}}{4} \end{array} \right.$$

Where

$f_{h,b,k}$ characteristic batten embedding strength [N/mm²]

$f_{h,r,k}$ characteristic rafter embedding strength [N/mm²]

β $f_{h,r,k} / f_{h,b,k}$

d outer thread diameter [mm]

t_b batten thickness [mm]

t_r lower value of rafter thickness or screw penetration length [mm]

t_{il} interlayer thickness [mm]

$M_{y,k}$ characteristic fastener yield moment [Nmm]

$F_{ax,Rk}$ characteristic axial capacity of the screw [N]

Thermal insulation on rafters with alternatively inclined screws

Mechanical model

Depending on the screw spacing and the arrangement of tensile and compressive screws with different inclinations the battens are loaded by significant bending moments. The bending moments are derived based on the following assumptions:

- The tensile and compressive loads in the screws are determined based on equilibrium conditions from the actions parallel and perpendicular to the roof plane. These actions are constant line loads q_{\perp} and q_{\parallel} .
- The screws act as hinged columns supported 10 mm within the batten or rafter, respectively. The effective column length consequently equals the length of the screw between batten and rafter plus 20 mm.
- The batten is considered as a continuous beam with a constant span $\ell = A + B$. The compressive screws constitute the supports of the continuous beam while the tensile screws transfer concentrated loads perpendicular to the batten axis.

The screws are predominantly loaded in withdrawal or compression, respectively. The screw's normal forces are determined based on the loads parallel and perpendicular to the roof plane:

$$\text{compressive screw: } F_{c,Ed} = (A + B) \cdot \left(-\frac{q_{\parallel}}{\cos\alpha_1 + \sin\alpha_1 / \tan\alpha_2} - \frac{q_{\perp} \cdot \sin(90^\circ - \alpha_2)}{\sin(\alpha_1 + \alpha_2)} \right)$$

$$\text{tensile screw: } F_{t,Ed} = (A + B) \cdot \left(\frac{q_{\parallel}}{\cos\alpha_2 + \sin\alpha_2 / \tan\alpha_1} - \frac{q_{\perp} \cdot \sin(90^\circ - \alpha_1)}{\sin(\alpha_1 + \alpha_2)} \right)$$

The bending moments in the batten follow from the constant line load q_{\perp} and the load components perpendicular to the batten from the tensile screws. The span of the continuous beam is $(A + B)$. The load component perpendicular to the batten from the tensile screw is:

$$F_{ZS,Ed} = (A + B) \cdot \left(\frac{q_{\parallel}}{1 / \tan\alpha_1 + 1 / \tan\alpha_2} - \frac{q_{\perp} \cdot \sin(90^\circ - \alpha_1) \cdot \sin\alpha_2}{\sin(\alpha_1 + \alpha_2)} \right)$$

Where

q_{\parallel} constant line load parallel to batten

q_{\perp} constant line load perpendicular to batten

α_1 angle between compressive screw axis and grain direction

α_2 angle between tensile screw axis and grain direction

A positive value for F_{ZS} means a load towards the rafter, a negative value a load away from the rafter.

Thermal insulation on rafters with alternatively inclined screws

Mechanical model

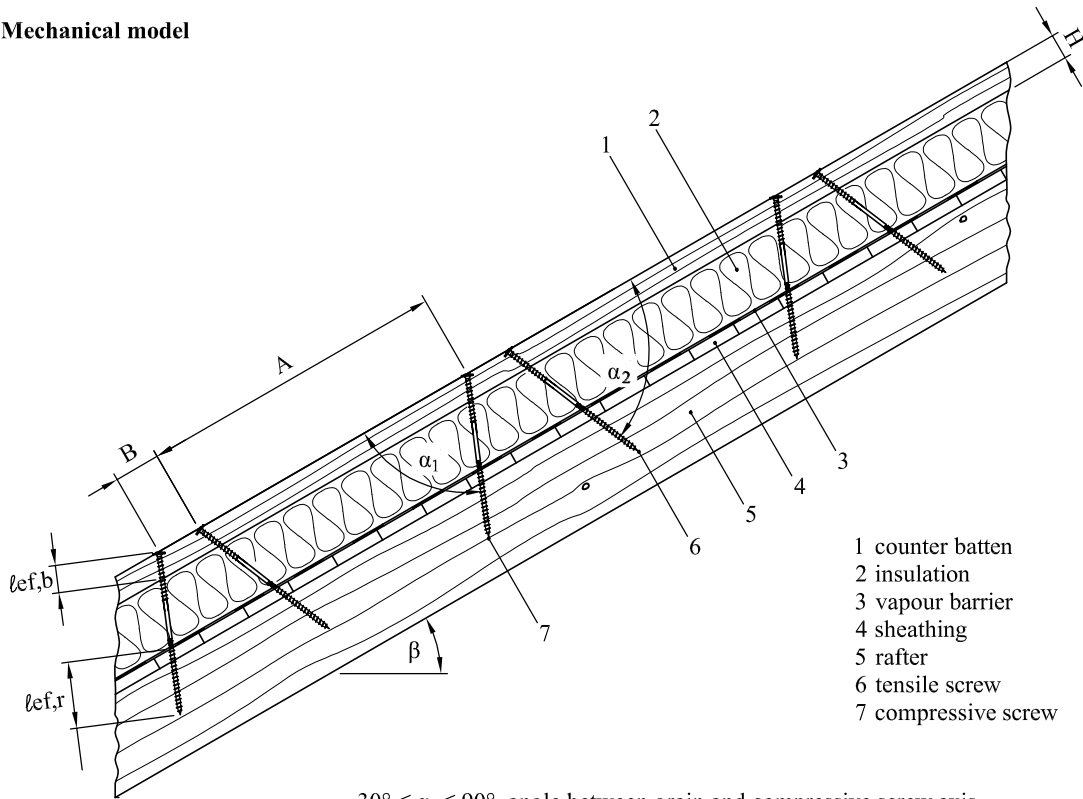

- 1 counter batten
- 2 insulation
- 3 vapour barrier
- 4 sheathing
- 5 rafter
- 6 tensile screw
- 7 compressive screw

$30^\circ \leq \alpha_1 \leq 90^\circ$, angle between grain and compressive screw axis
 $30^\circ \leq \alpha_2 \leq 90^\circ$, angle between grain and tensile screw axis

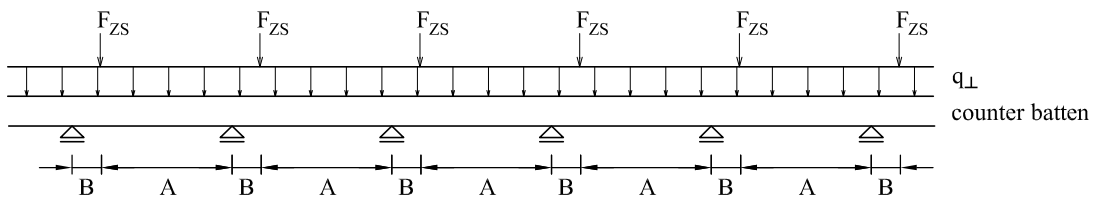

compressive screw:
$$F_{c,Ed} = (A + B) \cdot \left(-\frac{q_{\parallel}}{\cos\alpha_1 + \sin\alpha_1 / \tan\alpha_2} - \frac{q_{\perp} \cdot \sin(90^\circ - \alpha_2)}{\sin(\alpha_1 + \alpha_2)} \right)$$

tensile screw:
$$F_{t,Ed} = (A + B) \cdot \left(\frac{q_{\parallel}}{\cos\alpha_2 + \sin\alpha_2 / \tan\alpha_1} - \frac{q_{\perp} \cdot \sin(90^\circ - \alpha_1)}{\sin(\alpha_1 + \alpha_2)} \right)$$

concentrated load:
$$F_{ZS,Ed} = (A + B) \cdot \left(\frac{q_{\parallel}}{1 / \tan\alpha_1 + 1 / \tan\alpha_2} - \frac{q_{\perp} \cdot \sin(90^\circ - \alpha_1) \cdot \sin\alpha_2}{\sin(\alpha_1 + \alpha_2)} \right)$$

Where

q_{\parallel} constant line load parallel to batten

q_{\perp} constant line load perpendicular to batten

α_1 angle between compressive screw axis and grain direction

α_2 angle between tensile screw axis and grain direction

A positive value for F_{ZS} means a load towards the rafter, a negative value a load away from the rafter.

Thermal insulation on rafters with alternatively inclined screws

Design of the screws

The analysis of the fixing of the insulation and battens may be carried out using the static model showed on previous page. The battens must have sufficient strength and stiffness.

The design axial tensile capacity of the "KonstruX" or "Topduo" screws for rafter or facade insulation shall be calculated from:

$$F_{ax,a,Rd} = \min \left\{ \max \left\{ \begin{matrix} f_{head,d} \cdot d_h^2 \\ k_{ax} \cdot f_{ax,d} \cdot d \cdot \ell_{ef,b} \end{matrix} \right\} \cdot \left(\frac{\rho_{k,b}}{350} \right)^{0,8} ; k_{ax} \cdot f_{ax,d} \cdot d \cdot \ell_{ef,r} \cdot \left(\frac{\rho_{k,r}}{350} \right)^{0,8} ; \frac{f_{tens,k}}{\gamma_{M2}} \right\}$$

The design axial compressive capacity of the "KonstruX" or "Topduo" screws for rafter or facade insulation shall be calculated from:

$$F_{ax,a,Rd} = \min \left\{ k_{ax} \cdot f_{ax,d} \cdot d \cdot \ell_{ef,b} \cdot \left(\frac{\rho_{k,b}}{350} \right)^{0,8} ; k_{ax} \cdot f_{ax,d} \cdot d \cdot \ell_{ef,r} \cdot \left(\frac{\rho_{k,r}}{350} \right)^{0,8} ; \frac{F_{ki,Rk}}{\gamma_{M1}} \right\}$$

Where

- $F_{ax,a,Rd}$ design axial capacity of the screw at an angle α to the grain [N]
- $f_{head,d}$ design head pull-through parameter [N/mm²]
- d_h head diameter [mm]
- k_{ax} = 1,0 for $45^\circ \leq \alpha \leq 90^\circ$
= 0,3 + (0,7 · α /45°) for $0^\circ \leq \alpha < 45^\circ$
- $f_{ax,d}$ design withdrawal parameter [N/mm²]
- d outer thread diameter [mm]
- $\ell_{ef,b}$ length of the threaded part in the batten [mm]
- $\ell_{ef,r}$ point side penetration length of the threaded part according to EN 1995-1-1 [mm]
- α angle between grain and screw axis ($\alpha \geq 30^\circ$)
- $\rho_{k,b}$ characteristic density of the batten [kg/m³]
- $\rho_{k,r}$ characteristic density of the rafter [kg/m³]
- $f_{tens,k}$ characteristic tensile capacity [N]
- $F_{ki,Rk}$ characteristic compressive capacity depending on free screw length between counter batten and rafter [N]
- γ_{M1}, γ_{M2} partial safety factor according to EN 1993-1-1 or according to national annex

Free screw length [mm]	KonstruX					Topduo
	Ø6.5	Ø8.0	Ø9.0	Ø10.0	Ø11.3	Ø8.0
	$F_{ki,Rk}$ [kN]	$F_{ki,Rk}$ [kN]	$F_{ki,Rk}$ [kN]	$F_{ki,Rk}$ [kN]	$F_{ki,Rk}$ [kN]	$F_{ki,Rk}$ [kN]
< 120	2,32	4,28	8,56	6,76	18,80	5,97
140	1,75	3,27	6,62	5,21	14,90	4,59
160	1,38	2,57	5,25	4,12	12,00	3,62
180	1,10	2,08	4,26	3,33	9,85	2,93
200	0,91	1,71	3,52	2,75	8,20	2,42
220	0,76	1,43	2,97	2,31	6,93	2,03
240	0,64	1,21	2,52	1,96	5,92	1,72
260	0,55	1,04	2,17	1,69	5,12	1,48
280	0,48	0,91	1,89	1,47	4,48	1,29
300	0,42	0,79	1,66	1,29	3,94	1,13
320	0,37	0,70	1,47	1,14	3,49	1,00
340	0,33	0,62	1,31	1,01	3,12	0,89
360	0,29	0,56	1,17	0,91	2,80	0,80
380	0,26	0,50	1,06	0,82	2,52	0,72
400	0,24	0,46	0,96	0,74	2,29	0,65
420	0,22	0,42	0,87	0,68	2,09	0,59